

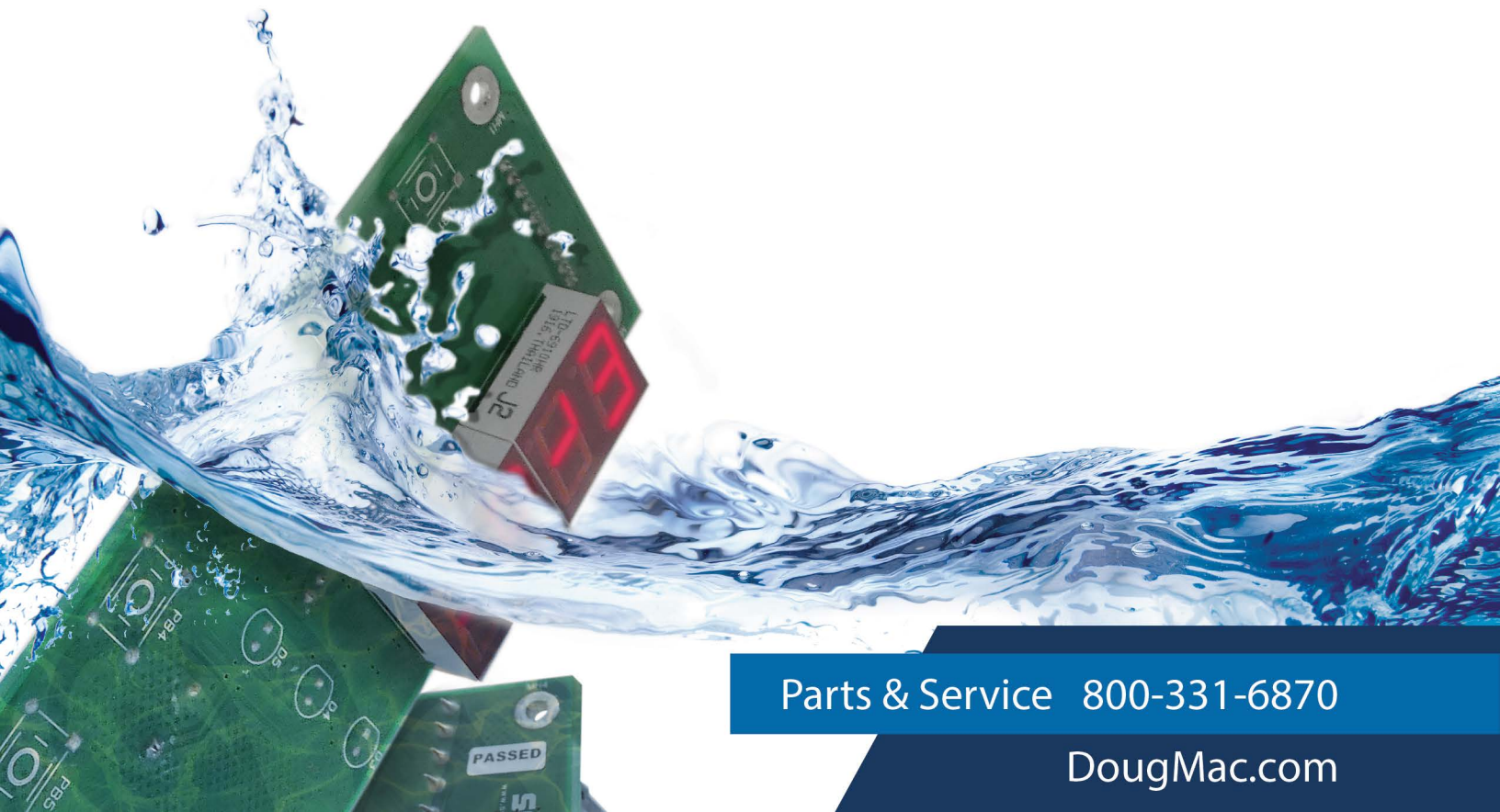

DOUGLAS
WASHING AND SANITIZING SYSTEMS

TROUBLESHOOTING



Parts & Service 800-331-6870

DougMac.com



DOUGLAS

WASHING AND SANITIZING SYSTEMS

Second Edition (April 2021)

*This book is a publication of Douglas Machines Corp. Service Department.
Future editions will reflect changes in procedures or technical details.*

Use and duplication of this document is encouraged.

For technical assistance, please call

1-800-331-6870.

© Copyright Douglas Machines Corp 2021.

SAFETY

Qualified installation personnel, individuals, firms, corporations, and companies are responsible for:

- 🔥 Wear appropriate P.P.E. ie... hearing protection, thermal resistant gloves, and eyewear.
- 🔥 Know where the **exits** are located.
- 🔥 Always turn off and drain the machine before entering. Allow a cool down period. Follow facility's L.O.T.O. procedure.
- 🔥 **Never** enter a machine where flooring has been removed. – Fall Hazard.
- 🔥 Use non-permit required confined space guidelines for entering.
- 🔥 When loading racks into the washers keep hands away from the door edges. Keep hands on the horizontal bars inside of the rack. Push the rack with both hands. **Do not** hold racks on the vertical support bars or outside edges. Never strain yourself to move racks if racks are too heavy unload some product.
- 🔥 Always use Caution. – Use mats to help reduce slip hazards.
- 🔥 Ensure that float switches and level probes are well maintained and cleaned daily. Failure to do so can result in unintended heater startup and potential fire.
- 🔥 **Never** leave your machine idle (not in use) for more than 4 hours. This can result in water evaporating out of the rinse tank causing damaging. Do not touch Rinse tank without a cool-down period.

TABLE OF CONTENTS

SECTION ONE

ELECTRICAL CONTROLS	5
MANUAL SWITCHES.....	5
WASH PUMP	8
SOLID STATE CUBE TIMERS.....	10
SETTING THE TIMES.....	13
DIGITAL TOUCHPAD.....	19

SECTION TWO

WASH SYSTEM.....	36
RUSSELL PUMP.....	36
RUSSELL PUMP/MOTOR ASSEMBLY.....	37
BURKS PUMP.....	38
GOULDS PUMP.....	42

SECTION THREE

HEATING SYSTEMS.....	49
ELECTRIC HEATING	49
MAXON BLOWER SYSTEM (CONT.).....	56
CARLIN GAS BURNER CONTROL	58
CARLIN GAS BURNER	66
TABLE FOR INFRARED BURNERS (CONT.).....	71

SECTION FOUR

RINSE/FILL SYSTEM.....	76
TROUBLESHOOTING RINSE WATER SYSTEM.....	77

SECTION FIVE

AUTO DRAIN	80
------------------	----

SECTION SIX

INSTALLATION OF UTILITIES.....	84
GAS.....	85
PLUMBING.....	86
DRAIN	87

SECTION SEVEN

REFERENCE	92
-----------------	----

MANUAL SWITCHES

Two types of controls use manual switches on the control panel.

Timers

One type of control uses timers for controlling the cycle times, and another uses a PC board. The timers were used on equipment built before 1996.

Omron Timers

Machines with Omron Timers and button controls have specific requirements.

Reference Table for Buttons and Contact Blocks

PART #	BUTTONS/BLOCKS	CONTACT BLOCK
1581	Off/On	1-KA2
3222	Off/On/Fill	1-KA2 + 1-KA3
1583	Start	1-KA2
1583	Stop	1-KA3
3284	Open/Close	1-KA2 + 1-KA3
1192	KA1-Clear	2 Contacts: 1 N.O. + 1 N.C.
0148	KA2-Green	1 Contact N.O.
0149	KA3-Red	1 Contact N.C.
1582	Short/Med/Long	1-KA2 + 2-KA3 (with Omron solid state timers)
1582	Short/Med/Long	2-KA3 (1827 board)

Note: Machines with Auto Drain replace KA2 contact block with a KA1 block on the Off/On or the Off/On/Fill switch.

Reference Table for Buttons and Switches

PART	NEMA 4 X
Push Button (Start or Stop)	1583
Pilot Light (Run)	10224
Short-Med-Long Switch	1582
Off/On Switch	1581
Off/On/Fill Switch	3222
Hub Jog Switch	*5001 with glove knob
Auto Drain	3284

Timer is to be operated in Mode A, Power On Delay Operation.

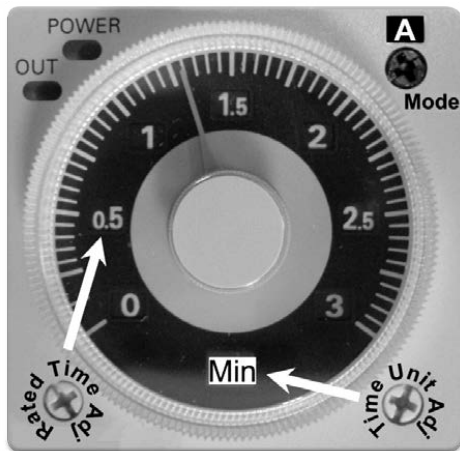

2709 Omron Timer

Units that are pre-1995 using an Omron timer system do not have Low Water Protection on the Wash pump.

Switch/Contact Type for Omron Timers

TERMINAL	SWITCH TYPE	CONTACT TYPE
1 + 3	Normally Open	Instantaneous contacts
1 + 4	Normally Closed	Instantaneous contacts
8 + 6	Normally Open	Timed contacts

8 + 5	Normally Closed	Timed contacts
2 + 7	Coil	100 - 240 VAC 50/60 Hz

Cycles for Systems with Two Timers

Timer 1	Wash Cycle	4 Minutes
Timer 2	Rinse Cycle	30 Seconds

Cycles for Systems with Three Timers

Timer 1	Wash Cycle	4 Minute
Timer 2	Rinse Cycle	30 Seconds
Timer 3	Fan Cycle	1 Minute

Switch/Contact Type for Omron Timers

Timer 1	Short Wash Cycle	4 Minute
Timer 2	Medium Wash Cycle	6 Minute
Timer 3	Long Wash Cycle	8 Minute
Timer 4	Rinse Cycle	30 Seconds
Timer 5	Fan/Dwell Cycle	1 Minute

Switch/Contact Type for Omron Timers

Timer 1	Short Wash Cycle	4 Minute
Timer 2	Medium Wash Cycle	6 Minute
Timer 3	Long Wash Cycle	8 Minute
Timer 4	Rinse Cycle	30 Seconds
Timer 5	Fan/Dwell Cycle	1 Minute
Timer 6	Auto Fill	Varies

Troubleshooting Table for Wash Pump Problems

PROBLEM	LIKELY SOURCE OF PROBLEM	CORRECTIVE PROCEDURES
Water Level	Low water protection component	Low water protection component may be preventing the pump from coming on. Low water probe may need cleaning if it is not sensing the water level when water is in the tank.
Wash Pump Will Not Start	Door	Door must be closed. Door must contact door switch Door switch must be in working order.
	Overload	Press the blue RESET button See <i>OVERLOADS</i> in the Reference Section.
	Circuit Breaker	If circuit breaker for pump motor is tripped, reset the breaker.
	Fuse	Check if fuses may be blown.
	Stop Button	Button is spring loaded and should return to outward position. If STOP button is stuck in, try pressing the button to reset.
	Timer One	Contact between Terminals #1 and #3 should be closed when START is pressed.

If all of these procedures fail to correct, see **Low Water System**.

Troubleshooting Table for Wash Heat Problem

PROBLEM	LIKELY SOURCE OF PROBLEM	CORRECTIVE PROCEDURES
Wash tank will not heat up	Water Level	Low water protection component may be preventing the heaters or the gas burner from turning on. Low water probe may need cleaning if it is not sensing the water level when water is in the tank.
	Power	Confirm that power is going to the element. Power to the wash thermostat should be 120V, ± 10 V from the low water protection circuit board and/or the solid state cube timer. (2" x 2" sq. - orange). Power to the wash contactor coil should be 120 V ± 10 V from the thermostat.
	Circuit Breaker	If circuit breaker for heater is tripped, reset the breaker.
	Fuse	Check all fuses in case any may have blown.

For gas heat, refer to the *Gas Heating: Maxon Blower System: Troubleshooting* section.

Omron Timer Flush Mount Kit for Obsolete Face Mount Timer

PART #	PART
2709	Omron Timer
2500	Plastic Retaining Ring
6227	Strainless Steel Adapter Plate (Douglas Mfg. part)

Timer Mounting Kit

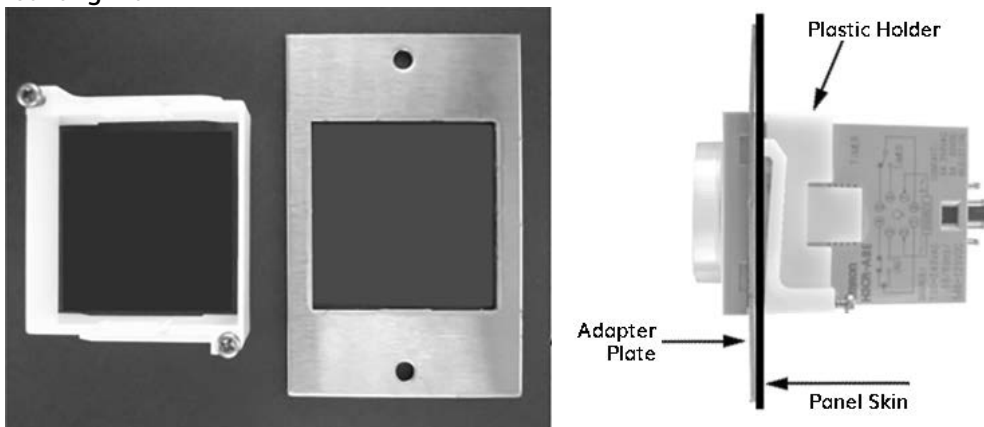

2500 Plastic Holder and 6227 S.S. Adapter Plate for Omron Timer shown in front and side views.

Solid State Cube Timers

The Solid State Cube timers control the cycles in the same way as the Omron timers; however, they use a resistor to set the desired time instead of an adjustable dial.



1531 Solid State Timer



1810 Solid State Timer



1867 Solid State Timer

NCC-Solid State Timers 1994-1996 Reference Table

PART#	TIMER	PURPOSE	RESITOR VALUE	APPROX. TIME
1867	Q2T	Auto Fill	None	3-60 Min. Adjustable
1810	Q4F	Short Wash Cycle Med. Wash Cycle Long Wash Cycle	390K OHM 680K OHM 1 Meg OHM	3.9 Minutes 6.8 Minutes 10 Minutes
1810	Q4F	Rinse Cycle	0 OHM	30 Seconds
1810	Q4F	Dwell/Unload Cycle	47K OHM	1 Minute
1531	Q1F	Heat Delay	0 OHM	15 Seconds
1810	Q4F	Pumped Auto Drain (UTC-6)	220K OHM	2.2 Minutes
1531	Q1F	Rinse Cycle (UTC-6)	0 OHM	15 Seconds

The solid state timer used for Auto Fill has an adjustable dial of 3 to 60 minutes.

NCC-Solid State Cube timers 1994-1996 Contact Type

TIMER	CONTACTS
Q2T	Normally open with momentary contact to close
Q4F	Normally closed
Q1F	Normally open

1827 PC Board

Board 1827 has been in use since 1999. Current NEMA 4X panels contain the 1827 board.

Technical Information

The controller is an open board construction intended to be installed inside of an electrical panel. The board operates on nominal 120 VAC line.

The basic function of the board is to control the operation of the unit, going through a cycle of Wash, Rinse, and then Fan (Dwell).

The six relays on the board control six outputs. One relay controls two of the outputs, and the sixth relay is a master control relay.

The outputs include a ready light, a fan, a heater contactor, a wash pump motor contactor, a rinse solenoid valve, and a fill valve.

1827 PC Board

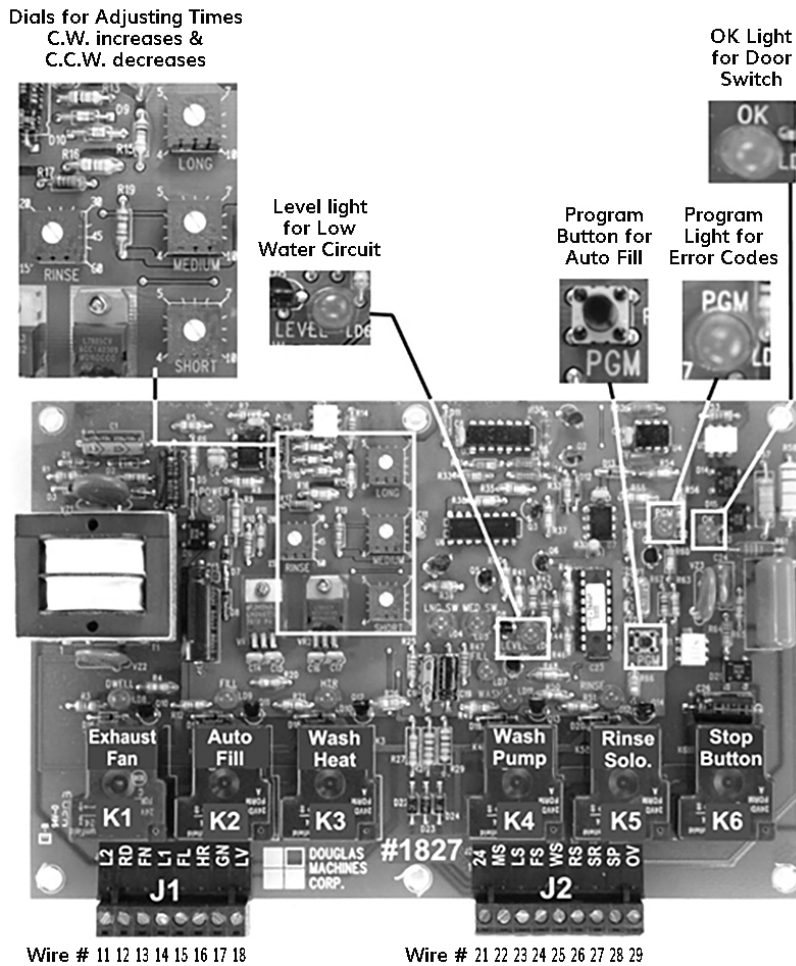

Three potentiometers control wash time: short, medium, and long cycles. Two switch inputs control which pot is selected. The Long switch selects the long pot, the Medium switch selects the medium pot, and the Short switch selects the short pot.

Routine Operation/Connections

1. Be aware that the board also controls a Fill cycle.
2. Note that the Fill cycle turns on the Fill valve and waits until the water level in the machine reaches the level probe.
3. At this point, the Fill valve is left on for the pre-programmed time to fill above the probe and then turned off.

Connection Table

FROM JACK #	TO WIRE #	BOARD MARK	PURPOSE
J1-1	11	L2	AC line L2 (neutral)
J1-2	12	RD	Ready light (Other side of light connects to L2)
J1-3	13	FN	Fan (Other side of fan connects to L2)
J1-4	14	L1	AC line L1 (hot)
J1-5	15	FL	Fill valve (Other side connects to L2)
J1-6	16	HR	Heater contractor coil (Other side connects to L2)
J1-7	17	GN	Chassis ground connection for level probe. NOTE: Not connected to logic common of the minus of the 24VDC
J1-8	18	LV	Liquid level detector probe or float switch
J2-1	21	24	+24VDC - Used for the Long, Medium and Fill switches
J2-2	22	MS	Medium wash time switch (Other side switch connects to +24)
J2-3	23	LS	Long wash time switch (Other side connects to +24)
J2-4	24	FS	Fill switch (Other side of switch connects to +24)
J2-5	25	WS	Wash pump contactor coil (Other side of coil connects to L20)
J2-6	26	RS	Rinse solenoid valve (Other side of solenoid connects to L2)
J2-7	27	SR	Start switch/run light (Connect other side of run light to L2) Connect other side of start switch to stop switch SP
J2-8	28	SP	Stop switch (Other side connects to L1. Door switch or E-stop may be placed in series.)
J2-9	29	OV	Motor overloads (Other side connects to L2)

Setting the Times

To set times on the 1827 PC board, several steps are required:

1. Open the control box.
2. Locate the PC board, a device approximately 8" x 5" with 6 relays and a transformer. The timer settings are located to the right of the transformer and are ½" blue squares with a white dial. They are labeled Long, Medium, Short, and Rinse.
3. To decrease the time, turn the timer counter-clockwise.
4. To increase the time, turn the timer clockwise.

Factory Settings

CYCLE	DURATION
Rinse	30 Seconds
Long	8 Minutes
Medium	6 Minutes
Short	4 Minutes

Note: The Rinse pot is fixed @ 30 sec. for NSF, and that non-NSF Rinse time is adjustable.

Programming the Auto Fill

1. Before starting, make sure there is no water in the machine and that the drain valve is closed.
2. Turn the Off/On/Fill switch to the On position, but make sure not to turn all the way to Fill.
3. Locate the Program button on the PC board. This black button is located on the right hand side just below the Program LED and labeled with the letters PGM.
4. Push in the PGM button but do not hold the button down, as it will then execute a test mode.
5. When the program light located above the button begins to flash, turn the Off/On/Fill switch to the Fill position.

The solenoid valve then opens and the machine begins to fill. When the water reaches the overflow level, turn the Off/On/Fill switch again to the Fill position.

6. Observe that the Fill Time is set.

Troubleshooting

To aid in troubleshooting, the PGM LED also serves as an error code indicator. In case of error, the LED flashes on and off at ½ second on and ½ second off and then pauses for 3 seconds.

The flashing pattern continues as long as the controller is in Idle Mode. The number of times the LED flashes between 3 second pauses indicates the number of the error.

Error Code Value Table

	PGM ERROR	INTERPRETATIONS
1	Watchdog timeout on filling to level probe	When the controller is in either a Fill cycle or a Teach Fill cycle, there is a 15 minute time limit until the water level reaches the level probe. If the fill valve is on for 15 minutes, the valve shuts off and the Fill cycle aborts. The controller reverts to Idle Mode.
2	Watchdog timeout on filling above the level probe	When in a Fill cycle or a Teach Fill cycle, there is a 5 minute limit for which the fill valve may be on after the water reaches the level probe. This error could occur in a Fill cycle only if an incorrect time were stored in the EEPROM or read from the EEPROM. This error could occur if the operator walked away from the machine while it was in Teach Mode. If this timeout occurs, the fill valve turns off and the machine returns to Idle Mode.
3	Loss of master control relay during machine cycle	This error could occur if the door was opened or if the motor overloads opened during a Wash or Rinse cycle.
4	Loss of water level during a machine cycle	This could occur in two situations: a) If the water in the machine drops during a cycle because a large container being washed is collecting wash water, or b) The water level in the machine is very low and the wash water circulating in the pump and plumbing is enough to lower the water level below the probe. The water level must be low for 5 seconds for the cycle to be aborted. The heater output will, however, be turned off immediately when the water level is below the probe.

Error Code Value Table (cont.)

	PGM ERROR	INTERPRETATIONS
5	EEPROM read error	Data stored in the EEPROM is redundant, and the two redundant numbers are compared. If they don't match, a read error is generated. This error could occur if a Fill cycle is started, but a Teach cycle has not been performed to program the Fill time. This should not occur, as Douglas will program a Fill time as part of the test procedure. The error could also occur if installing a new board.
6	Attempt to start a Fill cycle or Teach Fill cycle when the water level is already at the level probe	Clear the code by starting a new cycle.
7	Attempt to start machine cycle without water to the level probe	If unit has water and a clean low water probe, see <i>Low Water Section</i> .

1. Note that when one of these errors occurs, the controller reverts to Idle Mode.
2. Note that the error code flashes on the LED as long as it is in Idle Mode.
3. Note that as soon as a successful machine cycle, Fill cycle, or Teach Fill cycle executes, the error LED goes out.
4. There is no need to reset anything by turning the machine off.

For example, if the operator were to try to fill the machine a second time and the water were already at the level probe, nothing would happen. The error would flash on the PGM LED, but if the cover were on the electrical box, no one would see it. If the start button were then pressed, the error LED would go out and a normal machine cycle would be executed.

Troubleshooting Table for 1827 PC Board

PROBLEM	LIKELY SOURCE OF PROBLEM	CORRECTIVE PROCEDURES
Wash pump will not start	Door	<p>Make certain that the door is closed.</p> <p>Make certain that the door is contacting the door switch, or is within 1/8" of Prox switch.</p> <p>Check to see if the door switch is bad. If using a door switch, perform a continuity check.</p> <p>If using a Prox switch, jump out connections at PC board.</p> <p>Check to see if the OK LED on the PC board is illuminated.</p> <p>To see if the spring-loaded Stop button is stuck in, press it in again to make it return to an outward position.</p>
	Pump Motor	<p>Check to see if the pump motor overload has tripped.</p> <p>Press the Reset button on the overload (blue button located in the electrical panel). See Overloads in the Reference Section.</p>
	Circuit Breaker	<p>Check to see if the circuit breaker for the pump motor has tripped.</p> <p>Try resetting the breaker.</p>
	Pump motor fuses	<p>Check to see if any fuses for the pump motor are blown.</p> <p>Check all fuses.</p>
	Water	<p>Check to see if there is water in the tank.</p> <p>Low water protection component may be preventing the Wash pump from running.</p> <p>If there is water in the tank and the pump motor will not start, the low water probe in the tank may not be sensing the water.</p> <p>Clean the probe.</p> <p>Check the level LED on the PC board. It should be illuminated.</p> <p>If the PGM LED is flashing 7 times, it means that an attempt has been made to start a wash cycle without water to the level probe.</p> <p>See <i>Low Water Circuit: Control Type</i>.</p>

Troubleshooting Table for 1827 PC Board (cont.)

PROBLEM	LIKELY SOURCE OF PROBLEM	CORRECTIVE PROCEDURES
Machine will not go into Rinse cycle.	Door	Make certain that the door is closed. Make certain that the door is contacting the door switch.
	Rinse Solenoid	Check to see that the rinse solenoid is being energized when the Wash cycle times out. See 1827 PC Board: Routine Operation/Connections Table.
	Rinse LED	Ensure that the Rinse LED is illuminated on the PC board. If it is, then the problem is most likely at the solenoid.
Machine will not fill	Water	If there is water in the machine and it is above the water probe but the machine is not full, drop the water level below the probe. Restart the Fill. This condition will give an error code of 6 flashes on the PC board PGM LED (located in the electrical panel). Ensure low water probe is clean. It may be necessary to re-program Auto Fill time. Refer to 1827 PC Board: Setting the Times.
Wash tank will not fill completely	Water pressure	Proper water pressure to the machine is 60 psi static and 25 psi flow. If water pressure in the building has changed, the Fill cycle can be affected because the Fill cycle is timed. Fill time may need to be reprogrammed. See 1827 PC Board: <i>Programming the Auto Fill</i> .
	Auto Fill Power	If there is no power to the Auto Fill solenoid, refer to 1827 PC Board: Routine Operation/Connections.
Wash tank will not heat up	Low water	If there is no water in the tank, the low water protection component may be preventing the heaters or the gas burner from turning on. If there is water in the tank, the low water probe may need to be cleaned if it is not sensing the water level. Refer to <i>Low Water Circuit: 1827 PC Board</i> .

Troubleshooting Table for 1827 PC Board (cont.)

PROBLEM	LIKELY SOURCE OF PROBLEM	CORRECTIVE PROCEDURES
Wash tank will not heat up (cont.)	Wash T-stat power	Power to the Wash T-stat should be 120V \pm 10 V from the PC board, J1-6 Wire # 16.
	Wash contactor coil power	Power to the Wash contactor coil should be 120V \pm 10 V from the T-stat, Wire # 6.
	Heater circuit breaker	If the circuit breaker for the heaters has tripped, try to reset the breaker.
	Heater fuses	Check all heater fuses to see if they have blown.
	Gas heat	Refer to Gas Heating: Maxon or Infrared: Troubleshooting.
	LED	Verify that the level and HTR LED's are illuminated on the PC board.
Wash pump turns off during Wash cycle.	Pump motor overload	If the pump motor overload has tripped, press the Reset button on the overload (blue button in the electrical panel). Refer to Overloads in the Reference Section.
	PGM LED on PC board	If the PGM LED on the PC board is flashing 4 times, it is indicating that there is not enough water in the machine. Lower the water level below the level probe. Reprogram the Fill time. Refer to 1827 PC Board: <i>Programming the Auto Fill</i> .
	Excess water pressure	When the wash pump is started, the water pressure may be pushing against the door, causing the door switch to open. In this condition, the OK LED on the PC board would not be illuminated.
Rinse tank will not heat up.	Heater circuit breaker	If the circuit breaker for the heaters has tripped, reset the breaker.
	Heater fuses	Check all fuses in case any have blown.
	Rinse T-stat power	Power to the Rinse contactor should be 120V \pm 10 V from the T-stat Wire # 4.

DIGITAL TOUCHPAD

Technical Information

The Digital Touch Pad (Part # 3125) and PC Board (Part # 3126) have recently been updated. 3125 is now replaced by 5072, and 3126 is replaced with 5071.

The basic function of the board is to control the operations of the unit, going through a cycle of Wash, Rinse, and then Fan (Dwell). The touch pad display shows cycle countdown time and error codes.

3126 PC Board

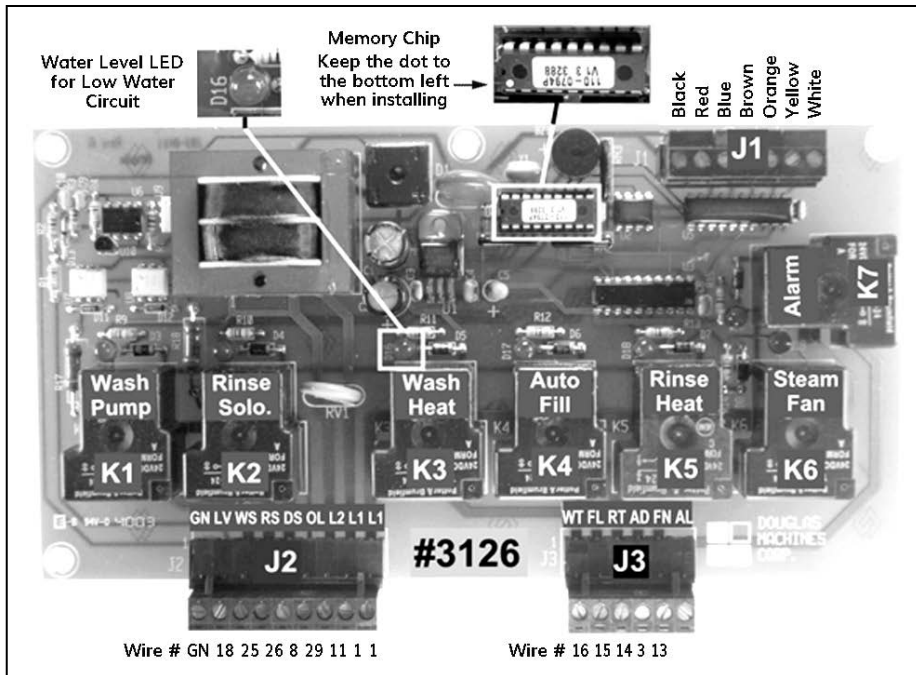

3125 Touch Pad for 3126 PC Board

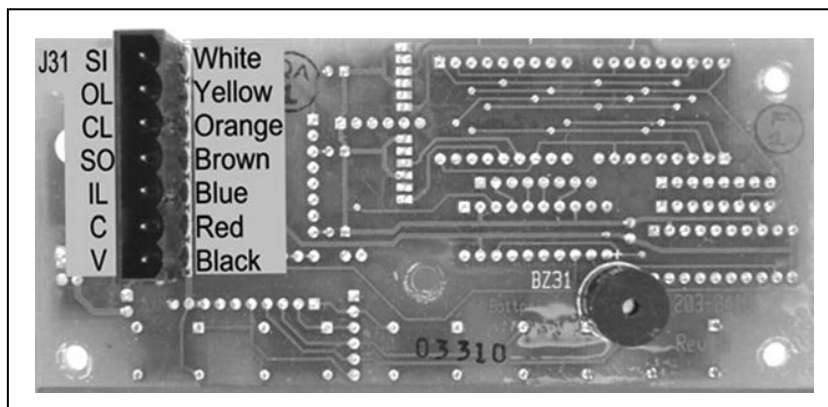

Use V and C to check for power to the Touch Pad.

10123

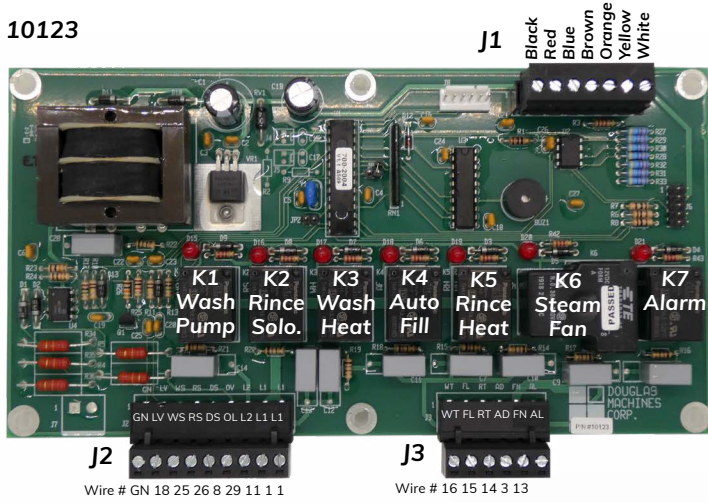

10124

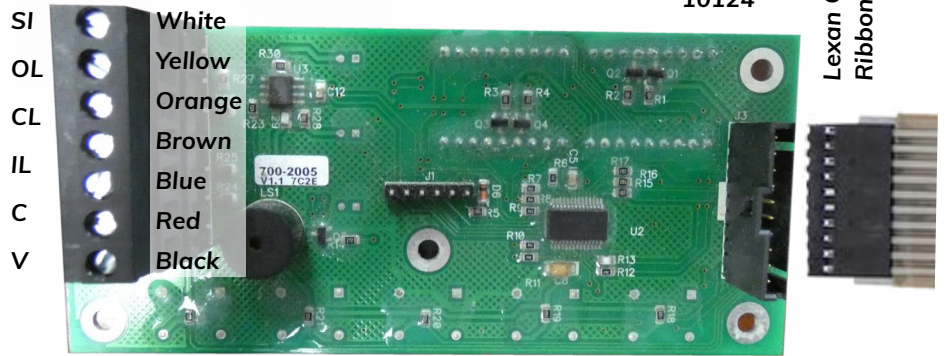

10791

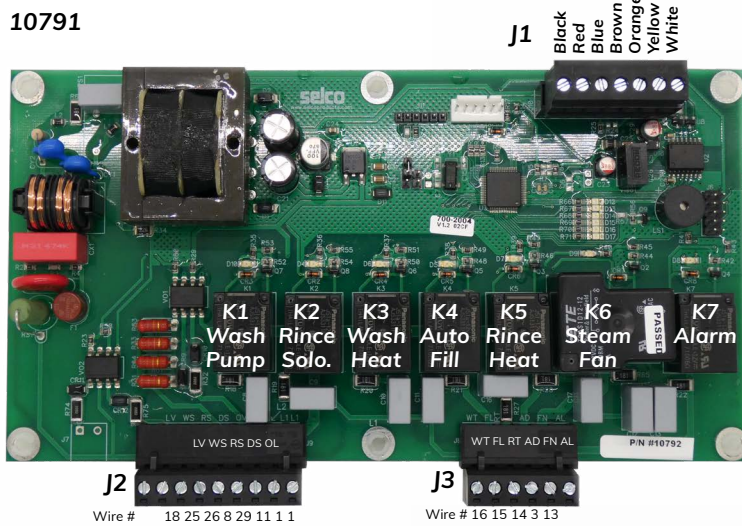

10792

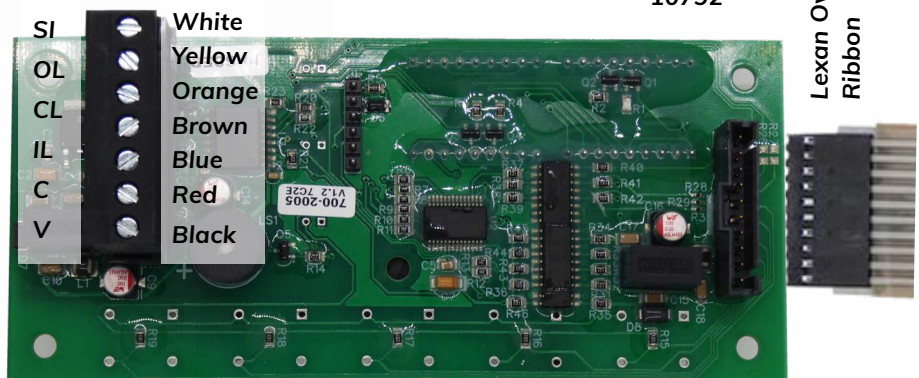

These instructions include how to program the control and describe the various timing ranges that can be set in programming, the default times, the error codes, and the specifics of what the readout will show during the various modes of operation and programming.

Dual Functions of Front Panel Buttons

NORMAL MODE FUNCTION	PROGRAMMING MODE FUNCTION
Short	Toggle
Medium	Down
Long	Up

In normal operation, a set chain of events completes a cycle.

1. To start the machine and light the display, push the Power button. The display flashes 00:00 until water touches the probe.
2. Observe that the display stops flashing and counts down the Fill time.
3. Observe that the machine fills, and that the wash heater is on anytime water is in contact with the probe.
4. Observe that when Fill is complete, digits read 00:00 and machine waits for a Wash button selection. Fill does not stop if the door is opened during the Fill cycle.
5. Select desired Wash cycle: Short, Medium, or Long. Display shows preset Wash time.
6. Observe that the Wash indicator light comes on when the Wash cycle starts.
7. Observe that the display counts down from the preset Wash time.
8. Observe that the Wash times out and Rinse starts. The display shows rinse time remaining and begins countdown.
9. Observe that Rinse light is lit.
10. Observe that Rinse times out. Buzzer beeps 3 times or until the Stop button is pushed or the door is opened.
11. Observe that the auxiliary output relay on the main board closes for 3 seconds, and then the exhaust fan comes on. Display shows the Unload time and begins countdown.

12. Observe that the Unload light is lit.
13. Observe that the Unload times out, and all lights go off. After the fan turns off, the display reads 00:00 and waits for a Wash selection.
Note: A short “beep” sounds any time an appropriate button is pushed, thereby giving an audible as well as a tactile feedback to the operator. Once a machine cycle begins, only the Power and Stop buttons will function. Opening the door or an interlock trip will act as a Stop and will cause an error code to appear on the display.

Programming

Before starting the programming, make sure that the 120 volt circuit is turned on, that there is no water in the wash tank, and that the drain valve is closed.

With the control voltage on, the colon on the touch pad display will be illuminated and flashing.

1. In order to make a programming change other than to the Auto Fill, fill the machine with water. Failure to do so will require starting with programming the Auto Fill and then proceeding to make the desired function change.
2. To initiate programming, press and hold the Stop button and then the Power button, holding both buttons at the same time until a beep sounds and four 0's (0.00:0) appear on the display.
3. Wait until the machine automatically fills with water until the level reaches the probe.
4. After that point, begin the programming. The programming for the fill of the wash tank will be first, and it may be the only function that needs to be programmed. All other functions are factory preset.
5. To program the Auto Fill, press the Long cycle button. The Fill process starts and the display timing begins.
6. After water level has reached the overflow, press the Medium cycle button. The flow of water stops and the time is displayed.
7. To enter the programmed time into the PC board, press the Short button.
8. After programming the Auto Fill, press the Short button to scroll through the remaining functions, either to exit the Program Mode or to make any changes to the following functions.

Digital Touch Pad Normal Settings

FUNCTION	TIME	
	MINUTES	SECONDS
Auto Fill	Variable	
Heater Delay		15
Short Wash Cycle	4	
Medium Wash Cycle	6	
Long Wash Cycle	8	
Rinse		30
Dwell and Fan	1	

9. To exit the Program Mode, scroll through remaining functions or press the Stop button for 2 seconds.
10. Note that the settings on these functions can be changed while viewing the preset times.
11. To decrease the time, press the Medium cycle button, and then press the Short button to enter the change.
12. To increase the time, press the Long cycle button, and then press the Short button to enter the change. If an error code is present in the display, it must be identified, resolved, and cleared from the PC Board.
13. To clear error codes from the touch pad display, press the Stop button.

To reset the PC board, you need to power down the digital display (colon illuminated only). Press the Stop button and hold it. Then press the Short cycle button and hold them both in at the same time.

You will hear a beep, and the unit will revert to the default times. When doing this on the 3126 board, you will need to reprogram the Auto Fill Time. If doing this on the 5071, 10123, & 10791 board, the Auto Fill Time will not be affected.

Connection Table for 3126, 5071, 10123, & 10791 Board

FROM JACK #	TO WIRE #	BOARD MARK	PURPOSE
J1-1	Black	V	10-14 VDC
J1-2	Red	C	10-14 VDC
J1-3	Blue	IL	Communication
J1-4	Brown	SO	Communication
J1-5	Orange	CL	Communication
J1-6	Yellow	OL	Communication
J1-7	White	SI	Communication
J2-1	Green	GN	Chassis ground for level probe *
J2-2	18	LV	Liquid level detector probe / Float Switch
J2-3	25	WS	Wash pump contactor coil
J2-4	26	RS	Rinse solenoid valve/rinse pump contactor coil
J2-5	8	DS	Door switch
J2-6	29	OV	Motor overloads
J2-7	11	L2	AC line (neutral)
J2-8	1	L1	AC line (hot)
J2-9	1	L1	AC line (hot)
J3-1	16	WT	Power to wash thermostat
J3-2	15	FL	Auto fill solenoid
J3-3	14	RT	Power to rinse thermostat
J3-4	3	AD	Power to auto drain switch
J3-5	13	FN	Steam exhaust fan
J3-6	N/A	AL	Power to optional bell

Connection Table for 3125, 5072, 10123, &10791 Touch Pad

FROM JACK #	TO WIRE #	BOARD MARK	PURPOSE
J31-1	White	SI	Communication
J31-2	Yellow	OL	Communication
J31-3	Orange	CL	Communication
J31-4	Brown	SO	Communication
J31-5	Blue	IL	Communication
J31-6	Red	C	10-14 VDC from PC Board
J31-7	Black	V	10-14 VDC from PC Board

* PC Board 10791 must operate with a 2-Wire N.O. Float Switch. Wires to be connected to 120V Neutral (#11) & J2-2 (#18)(J2-1 Empty)

The 5071 PC Board was released into production in July 2004.

5071 PC Board

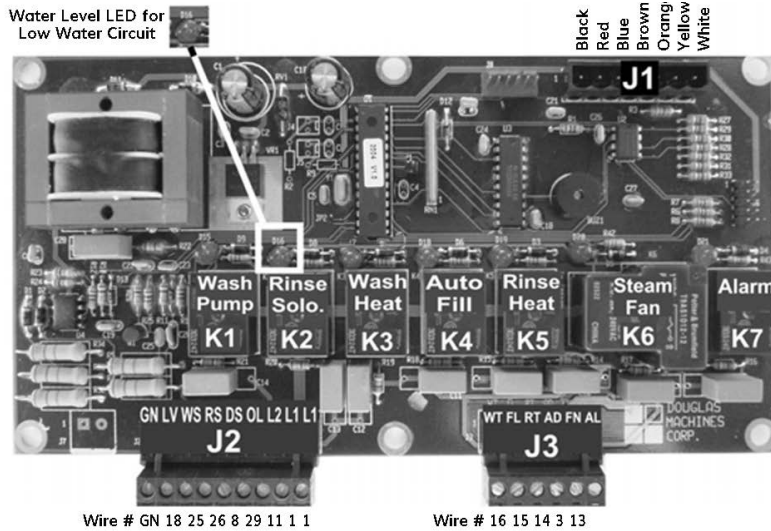

5072 Touch Pad

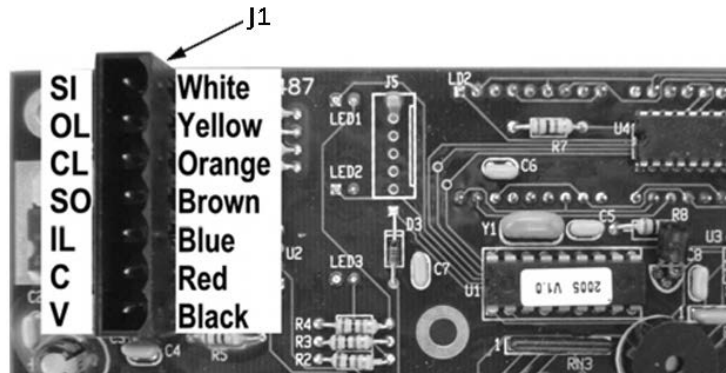

Troubleshooting

Touch Pad Error Code Value Table

ERROR CODE	INTERPRETATIONS
Er01	The machine has exceeded the allowable fill time, indicating low incoming water pressure or that the drain valve has been left open.
Er02	The Stop button has been pressed during the Wash cycle.
Er03	Excessive water loss occurred during operation.
Er04	Control board error has occurred. Reprogramming may be required.
Er05	Operation of the machine has been attempted without adequate water in the wash tank.
Er06	Door has not closed properly.
Er07	Pump overload device has been tripped.

Light and Decimal Points during Programming Mode

CYCLE	INDICATOR	TIME	
		ON	OFF
Auto Fill	Displays 0.0.00 before water hits Low Water probe. Displays 0.0.00 and counts up after water hits Low Water probe.	N/A	N/A
Delay (heater)	Flashing colon	.5	.5
Short Wash	Wash light and first decimal point flash	5 sec.	5 sec.
Medium Wash	Wash light and fourth decimal point flash	5 sec.	5 sec.
Long Wash	Only the wash light flashes	5 sec.	5 sec.
Rinse	Rinse light	On	On
Unload	Unload light	On	On

Program Modes and Default Times

Troubleshooting Table for 3126, 5071, 10123, & 10791 PC Board

PROBLEM	LIKELY SOURCE OF PROBLEM	CORRECTIVE PROCEDURES
Wash pump will not start	Door	<p>If Error Code 06 is shown on the touch pad, it indicates that the door is open. Make sure the door is closed.</p> <p>Ensure the door is contacting the door switch, or is within 1/8" of Prox switch.</p> <p>If using a door switch, ensure the switch is not bad. Perform a continuity check.</p> <p>The Prox switch could be bad.</p> <p>Jump out connections on PC Board.</p>
	Pump motor overload	<p>If Error Code 07 is shown on the touch pad, it indicates that the motor overload has tripped.</p> <p>Try pressing the Reset button on the overload (blue button, located in the electrical panel).</p> <p>Refer to Overloads in the Reference Section.</p>
	Pump circuit breaker	<p>If the circuit breaker for the pump motor is tripped, reset the breaker.</p>
	Pump motor fuses	<p>Check all fuses in case any are blown.</p>
	Water	<p>Ensure that water is in the tank.</p> <p>The low water protection component may be preventing the Wash pump from running.</p> <p>If there is water in the tank and the pump motor will not start, the level probe may not be sensing the water. Error Code 05 on the touch pad indicates that the level probe is not contacting the water.</p> <p>Clean the probe / float switch.</p> <p>Refer to <i>Low Water Circuit: Digital Touch Pad 3126</i> for more info.</p>

Troubleshooting Table for 3126 or 5071 PC Board (cont.)

PROBLEM	LIKELY SOURCE OF PROBLEM	CORRECTIVE PROCEDURES
Machine will not go into Rinse cycle.	Door	Make sure that the door is closed. Make certain that the Prox switch is within 1/8" of the door.
	Rinse solenoid	Verify that the rinse solenoid is being energized when the wash cycle times out. Refer to <i>Troubleshooting the Rinse Water</i> for more info.
	Rinse LED	The Rinse LED should be illuminated on the touch pad.
Machine will not fill	Water	If the machine is empty and the touch pad displays an illuminated and flashing colon, the machine will fill with water by depressing the Power button. If the machine will not fill, the level probe may be dirty. Clean the level probe / float switch. Check that the LED for Relay D-16 is illuminated.
	Water pressure	If the wash tank does not fill completely, check for changes in the water pressure in the building. Fill cycle is timed and it can be affected by abnormal water pressure. Fill time may need to be reprogrammed. Proper water pressure to the machine is 60 psi static and 25 psi flow. See <i>Digital Touchpad: Programming</i> .
	Auto fill power	Verify that power is getting to the Auto Fill solenoid. Wire # 15 to Neutral should be 120 V.
Wash tank will not heat up	Water	Confirm that water is in the tank. Low water protection component may be preventing the heaters or the gas burner from turning on. If there is water in the tank, the low water probe / float switch may need to be cleaned if it is not sensing the water. Refer to <i>Low Water Circuit/ Digital Touch Pad 3126</i> .

Troubleshooting Table for 3126 or 5071 PC Board (cont.)

PROBLEM	LIKELY SOURCE OF PROBLEM	CORRECTIVE PROCEDURES
Wash tank will not heat up (con't.)	Wash T-stat power	Verify that power is getting to the Wash T-stat. Power should be 120 V \pm 10 V from the PC board, J3-1 Wire # 16.
	Wash contactor coil power	Confirm that power is getting to the Wash contactor coil. Power should be 120 V \pm 10 V from the T-stat Wire # 6.
	Heater circuit breaker	If the circuit breaker for the heaters has tripped, try to reset the breaker.
	Heater fuses	Check all heater fuses to see if any have blown.
	Gas heat	Refer to <i>Gas Heating: Maxon or Infrared: Troubleshooting</i> .
	LED	The LED for D-16 relay should be illuminated on the PC board.
Wash pump turns off during wash cycle.	Pump motor overload	If the pump motor overload is tripped, Error Code 07 appears on the touch pad. Try pressing the Reset button on the overload (the blue button located in the electrical panel). Refer to <i>Overloads</i> in the Reference Section.
	Not enough water	If Error Code 03 appears on the touch pad, there is inadequate water in the machine. Put the water level below the level probe, and refill the machine. Cycle the power on the touch pad off and then on. Machine should fill to proper level. If not, Fill time needs to be reprogrammed. Refer to <i>Digital Touch Pad: Programming</i>
Wash pump turns off during wash cycle (cont.)	Door	Make sure the door is closed. When the Wash pump is started, the water pressure may be pushing against the door and causing the door switch to open. Error Code 06 would be shown on the touch pad.

Troubleshooting Table for 3126 or 5071 PC Board (cont.)

PROBLEM	LIKELY SOURCE OF PROBLEM	CORRECTIVE PROCEDURES
Rinse tank will not heat up.	Heater circuit breaker	If the circuit breaker for the heaters has tripped, reset the breaker.
	Heater fuses	Check all fuses for the heaters to see if any have blown.
	Rinse T-stat power	Verify that power is getting to the Rinse T-stat. Recommended power is 120 V ±10 V from J3-3 Wire # 14 on the PC board.
	Rinse contactor power	Recommended power is 120 V ±10 V from T-stat Wire # 4. Note: Rinse tank should be full of water at all times.

LOW WATER CIRCUIT

0178 Low Water Probe

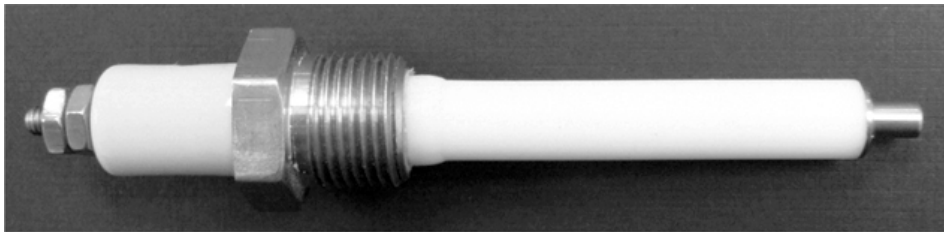

1900 Float Switch



ITEM #	DOCUMENT #	TITLE	MATERIAL	DP #	QTY
1'	00-980-00-123	Nipple, Bushing, Float, Conversion	1" Round STK SS		1

Lower Water Probe to Float Conversion Kit

2'	.5 X .25 Pipe Bushing SS 304	.5 X .25 Pipe Bushing SS 304	Stainless Steel, 316	1001	1
4'	.5 Pipe Full Coupling SS	.5 Pipe Full Coupling SS	Stainless Steel, 304	0029	1
5'	Float Switch Level LS-7	Float Switch Level LS-7	Plastic	1900	1

1827 PC Board

On units using the 1827 PC Board, the low water circuit is built into the board.

1. To confirm that the circuit is working, check to confirm that the LED light labeled Level is On.
2. If the Level light is not on, remove the wire from the outside of the low water probe.
3. Ground it to the chassis of the machine.
4. If the Level light comes on, it means that the problem is a dirty or bad low water probe.
5. If the light still does not come on, then the problem is in the PC Board.

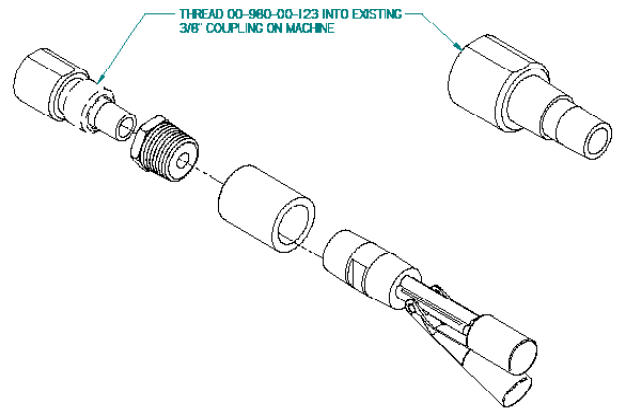
**Digital Touch Pad 3126, 5071, & 10123**

On units using a 3126 or 5071 PC Board, the low water circuit is built into the board.

1. To confirm that the circuit is working, check to confirm that the LED above Relay D-16 is On.
2. If the LED is not on, remove the wire from the outside of the low water probe.
3. Ground it to the chassis of the machine.

0612 Low Water Board

- If the relay light comes on, the problem is a dirty or bad low water probe.
- If the light still does not come on, the problem is in the PC board.

Digital Touch Pad 10791

On units using a 10791 circuit board, the low water circuit is built into the board.

- To confirm that the circuit is working, check to confirm that LED D6 on the main PC Board is illuminated.
- If the LED is not illuminated, check the operation of the float switch in the wash tank.
- The switch should be in a normally open position, when the water level rises and lifts the float the switch becomes closed.
- If the float switch circuit is closed and there is no continuity to the PC Board (No LED D6) then the float switch maybe temporarily bypassed to troubleshoot the low water circuit.

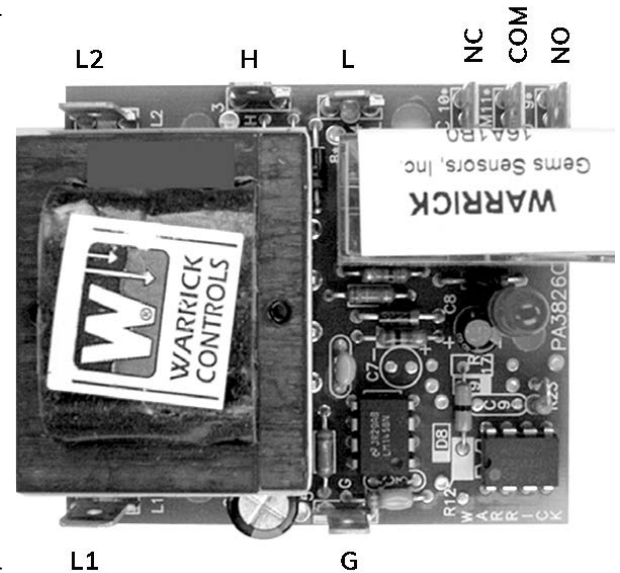

LOW WATER PROTECTION CIRCUIT BOARD 0612

The Low Water Protection Circuit Board (Part # 0612) Single Probe was in use prior to 1993.

This board is used to protect the Wash tank heat source from being used without the proper amount of water in the tank.

- Verify that power goes to the board (120 V).
- Check for voltage at L1 to L2 and COM. to L2 to confirm 120 V.

Voltage Table

CONNECTION	FUNCTION
L1	Hot 120 V
L2	Neutral
COM	Hot 120 V
G	Jumper wire to chassis
H	Wire to low water probe
L	Not used
N.C.	Not used
N.O.	Hot wire to thermostat

When water level contacts probe, connection from G to H is made and N.O. contact closes, providing power to Thermostat (120 V).

3. Check to see if water is contacting the probe inside the tank.
4. Remove any debris from the probe. Debris can cause it to not sense water, or it can coat it with a substance that would act like it was in water when it really is not.
5. To bypass the probe and check board operations, remove the wire at the probe and touch it to the chassis.

Low Water Protection Circuit Board 0615

The Low Water Protection Circuit Board (Part #0615) Single Probe was in use prior to 1993.

This board is used to protect the Wash tank heat source from being used without the proper amount of water in the tank.

If the machine has an 1827 or a 3126 PC Board for controls, then this board will be used only for pumped rinse protection.

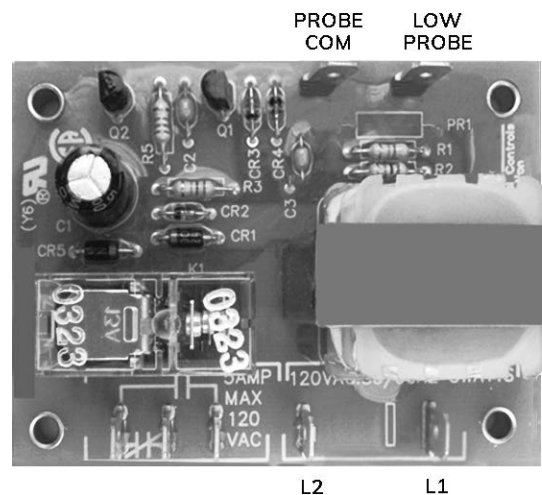

Note: This board is also used on machines that have a pumped rinse tank to protect the

heat source and the pump. It has only been used to protect the pump since 2001.

If there is a time delay installed in the low water protection circuit, it is a 2" square orange component. It is wired in series with low water board and the thermostat.

1. Verify that power goes to the board (120 V).
2. Check for voltage at L1 to L2 and COM. to L2 to confirm 120 V.

Connection Table

CONNECTION	FUNCTION
L1	Hot 120 V
L2	Neutral
COM	Hot 120 V (Far left bottom of board)
N.C.	Hot wire to Thermostat or to Cube timer if there is a delay.
N.O.	Not used
Probe Com	Jumper wire to chassis
Low Probe	Wire to probe (blue)

3. Check to see if water is contacting the probe inside the tank.
4. Remove any debris from the probe. Debris can cause it to not sense water, or it can coat the probe with a substance that would make the probe act as though it were in water even when it is not.
5. To bypass the probe to check the operation of the board, disconnect the wire at the probe and touch it to the machine chassis.

When the water level contacts the probe, a connection is made from probe COM. to low probe terminals. This closes the relay contact between COM. and N.O., providing 120 V to Thermostat.

Auto Fill Circuit Board Two Probe 0613

The Auto Fill Circuit Board Two Probe has been in use since 1992.

This board is used to fill and maintain the water level in a pumped rinse tank. This board was also used for Water Level control on the Wash

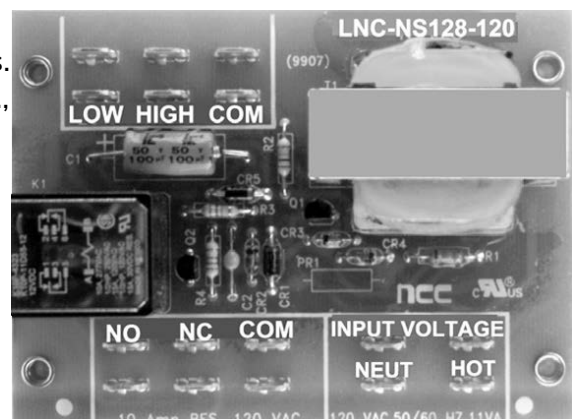

0613 Two Probe Low Water Board

tank between 1992 and 1994.

Normal Operation

There are two male spade terminal connection points that are common to each.

Voltage Table

CONNECTION	FUNCTION
Low	Wire to middle probe in tank
High	Wire to top probe in tank
COM	Jumper wire to chassis
N.O.	Hot wire to Auto Fill solenoid
N.C.	Not used
COM	Hot wire to 120 V
Input voltage	Neutral wire to 120 V
Input voltage	Hot wire to 120 V

1. Observe that when the water level reaches the top probe, the fill solenoid valve shuts off.
2. Observe that when the water level drops below the middle probe, the fill solenoid valve turns on.

The bottom probe in the tank operates from a different board (# 0615, low water protection).

SECTION TWO

WASH SYSTEM*Russell Pump*

The Wash pump system is designed to recirculate the wash water and to bring the wash pressure up to 35 psi plus, depending on the model and arm system.

**NOTE: The Russell Pump assembly is very similar to Burks.
see the Burks section for replacing the seal kit.**

Russell Pump Parts Matrix

PART DESCRIPTION	5 H.P.	7.5 H.P.	NOTE:
Casing	10291	10291	Cast Iron
Adapter	10292	N/A	ODP/TEFC/WD
Adapter	N/A	10292	ODP
Adapter	N/A	10293	TEFC/WD
Impeller	10294	N/A	6" Dia. Bronze
Impeller	N/A	10295	6.25" Dia. Bronze
Shaft Sleeve	10296	10296	Brass
Impeller Washer	10297	10297	Brass
Impeller Bolt	10298	10298	
Impeller Key	10299	10299	Stainless Steel
Mechanical Seal	10300	10300	
Casing O-Ring	10301	10301	
Impeller Washer O-Ring	10302	10302	
Impeller O-Ring	10303	10303	
Seal Kit	10304	10304	
Wet End Kit	10305	N/A	OPD/TEFC/WD
Wet End Kit	N/A	10306	ODP
Wet End Kit	N/A	10307	TEFC/WD

Russell Pump/Motor Assembly

Mechanical Seal Kit

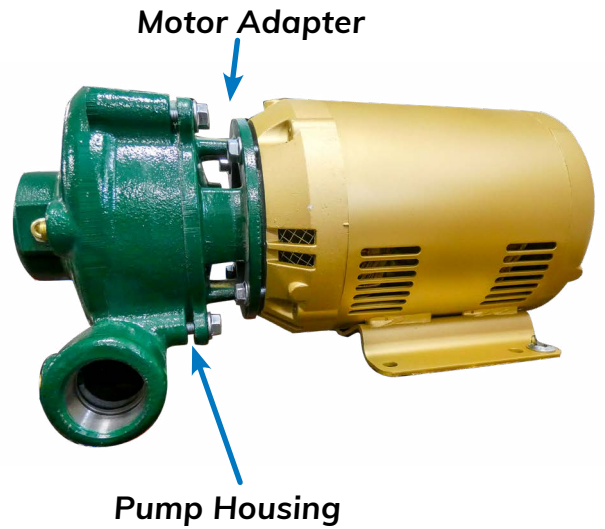
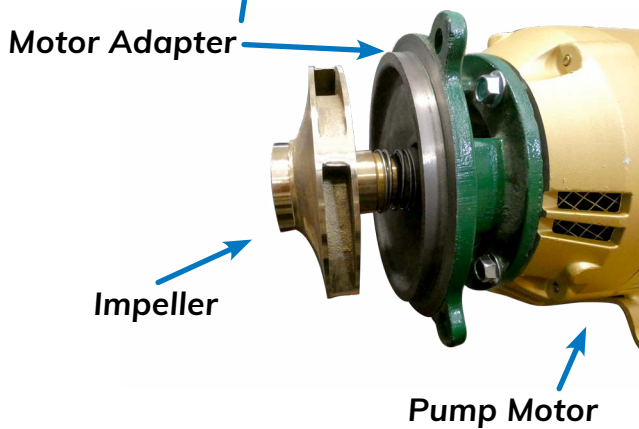
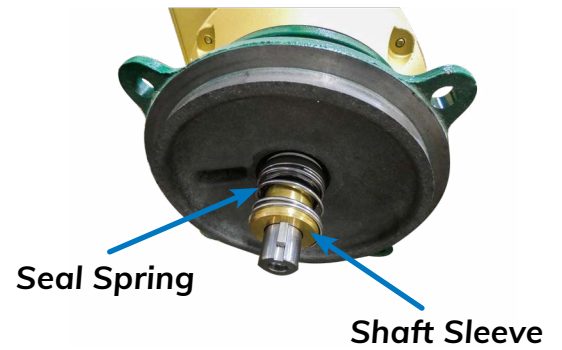
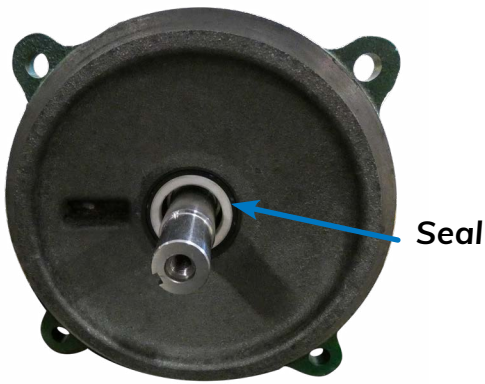
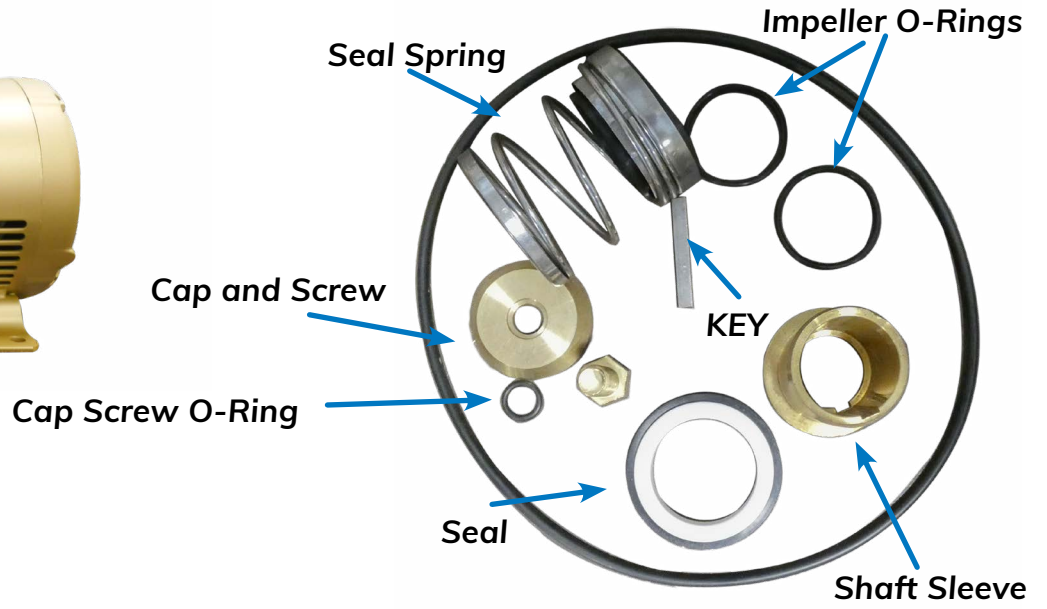

Burks Pump

The Wash pump system is designed to recirculate the wash water and to bring the wash pressure up to 35 psi plus, depending on the model and arm system.

Burks 1997 to present**Burks' Pump Parts Matrix**

PART DESCRIPTION	5 H.P.	7.5 H.P.	15 H.P	20 H.P	25 H.P
Complete Pump & Motor 1ph	2353	2381	N/A	N/A	N/A
Complete Pump & Motor 3ph	2313	2314	2315	2369	6349
Motor (3 phase)	3275	3134	3208	3135	3936
Motor (single phase)	3438	3437	N/A	N/A	N/A
Wet End Kit (everything but motor)	3648	3437	3598	3647	4823
Adapter	4913	4911	4171	3594	3594
Pump Housing	4914	3596	4912	3592	3592
Impeller	3439	3411	3595	4138	4421
Mechanical Seal Kit	2339	2339	2339	2692	2692
Casing O-Ring	2342	2342	2341	2885	2885
Impeller O-Ring (need 2)*	2338	2338	2338	3543	3543
Rubber Slinger Washer	3684	3684	3684	3542	3542
Impeller Washer O-Ring	2337	2337	2337	3518	3518
Shaft Sleeve	2340	2340	2340	2886	2886
*When ordering #3543 you only need to order one. Also order one #3440					

Replacing the Mechanical Seal - Burks

The procedure for replacing the mechanical seal requires the sequence indicated.

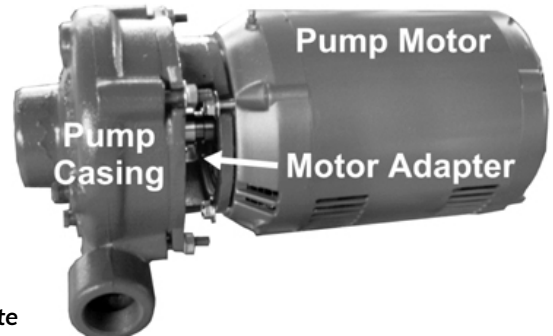

Burks Complete

1. Remove the 4 nuts holding the pump housing to the motor adapter. This will expose the pump impeller.

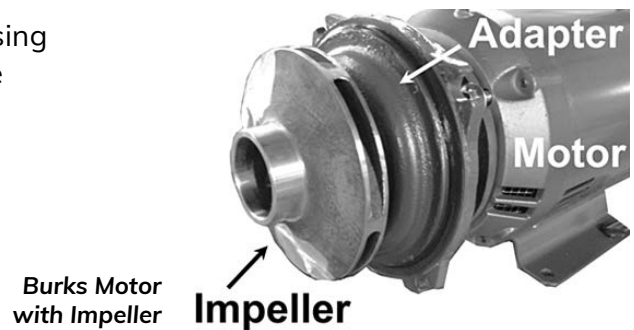

Burks Motor with Impeller

2. Remove the cap screw from the center of the impeller. Carefully remove the impeller from the motor shaft and slide the seal spring and shaft sleeve off the motor shaft away from the adapter plate.

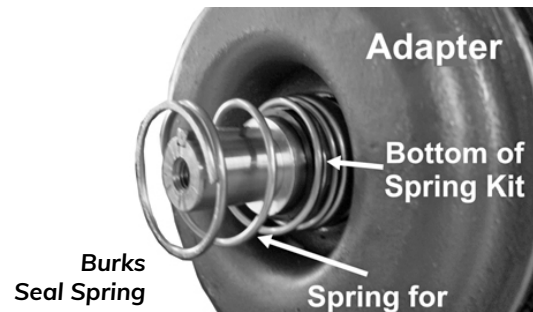
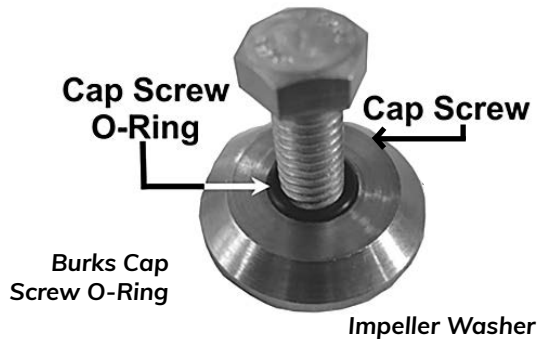

3. Remove the old ceramic seal from the inside of the adapter plate. Note: It may be necessary to remove the adapter plate from the motor to remove the ceramic seal.
4. Using a water based lubricant, install the new adapter seal with the ceramic side out into the motor adapter plate. **NOTE:** If it was necessary to remove the adapter, reinstall it on the motor now, taking care not to damage the new seal.



Burks Adapter and Seal

5. Install the bottom of the seal kit on the shaft sleeve using water based lubricant. Install the shaft sleeve on the motor taking care to align the sleeve with the shaft key-way.

Burks Shaft Sleeve

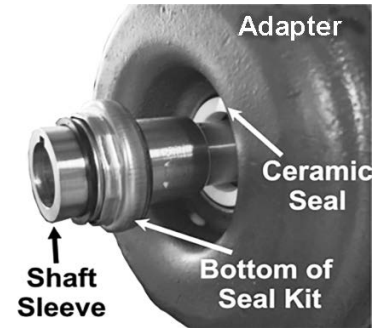

6. Slide the shaft sleeve with the large end of the seal down the shaft until it bottoms out on the shaft. Note: the sleeve should slide inside the white ceramic seal.

Burks Seal

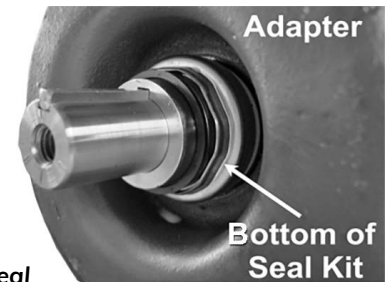

7. Install the seal spring over the shaft. Ensure it seats to the bottom of the seal kit.

Burks Seal Spring

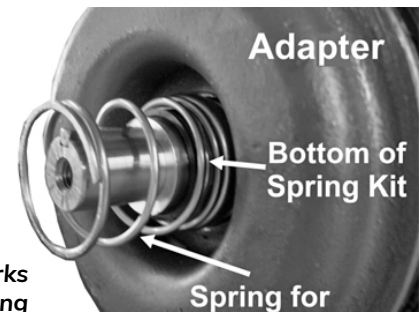

8. Install the new O-rings into the seal seat on both sides of the impeller.

Burks Impeller O-Ring

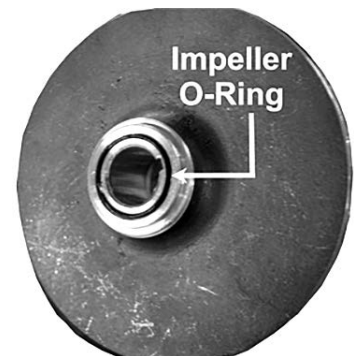

- Reinstall the impeller wheel on the motor shaft ensuring that the seal spring rides in the step on the base of the impeller wheel

Burks Impeller
Spring Seat

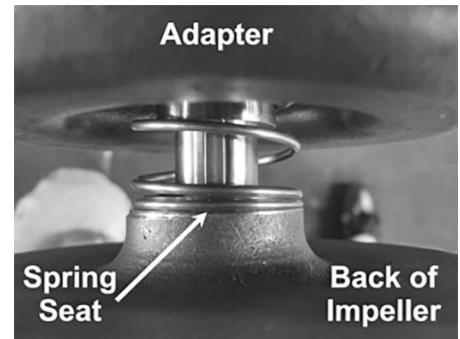

- Install the new cap screw O-ring and reinstall the cap screw into the end of the motor shaft, securing the impeller in place.

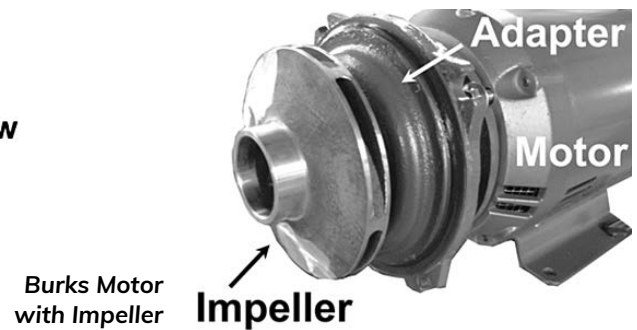

- Reinstall the pump casing.

Goulds Pump

1½" Discharge

3" Discharge

Goulds Pre-1997

Goulds' Pump Parts Matrix

PART DESCRIPTION	5 H.P.	7.5 H.P.	7.5 H.P.	15 H.P.
Complete Pump & Motor 1ph	0270	N/A	N/A	N/A
Complete Pump & Motor 3ph	0271	0272	1692	0497
Motor (3 phase)	3275	3134	3208	3208
Motor (single phase)	3438	3437	3437	N/A
Wet End Kit (everything but motor)	3066	3043	3143	3217
Adapter	5062	5249	5066	5066
Pump Housing	5061	5249	4809	4809
Impeller	3273	3048	3084	3274
Mechanical Seal Kit	1138	1138	1138	1138
Casing O-Ring	0750	0750	1478	1479
Shaft Sleeve	1990	1990	1990	1990
Brass Casing Wear Ring	5063	5063	4676	4676
Impeller Key Stock	4392	4392	4392	4392

Replacing the Mechanical Seal - Goulds

The procedure for replacing the mechanical seal requires the sequence indicated.

1. Remove the 6 bolts holding the pump housing from the adapter plate. Then remove the impeller, spring, sleeve and black ceramic seal from the motor shaft, and the O-ring from the outer adapter plate edge.
2. Remove the adapter plate and push the white ceramic seal out from the adapter plate. Reinstall the adapter plate on the motor and using a water based lubricant, install the ceramic seal with the rubber side into the adapter plate, with the white ceramic side facing out.
3. Using a water based lubricant, install the shaft sleeve on to the motor shaft and slide it into the ceramic seal Until it seats.
4. Install the seal spring on to the shaft.

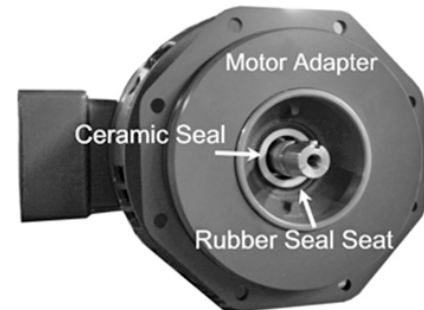

**Goulds Motor Adapter
with Ceramic Sleeve**

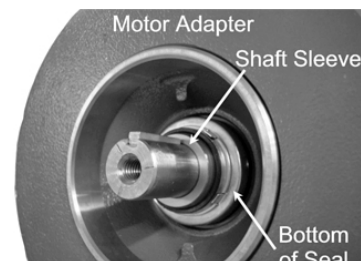

**Goulds Motor Adapter
with Shaft Sleeve**

**Goulds Motor Adapter
with Seal Spring**

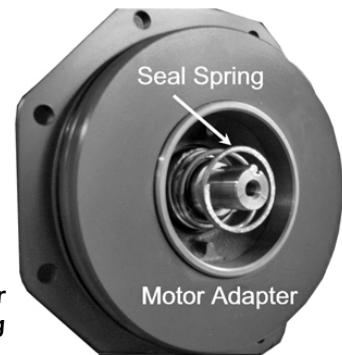

- Using a water based lubricant, install the large O-ring on the adapter plate, and reinstall the impeller on to the shaft.

Goulds Overview

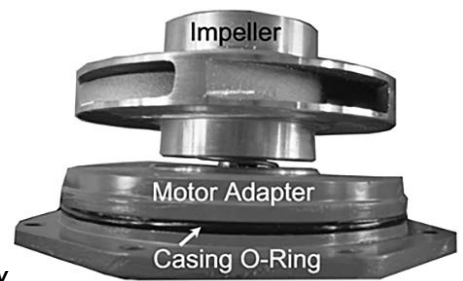

- Reinstall the pump housing, taking care to seat it cleanly on the adapter plate O-ring. Install the 6 bolts securing the pump housing to the adapter plate.

**Goulds Pump and
Motor Assembly Complete**



Pump Troubleshooting

Troubleshooting Table for Pump Problems - All Models

PROBLEM	LIKELY SOURCE OF PROBLEM	CORRECTIVE PROCEDURES
Low jet pressure	Wash arm end cap	If the wash arm end cap is missing, install a new one.
	Excess soap	If it appears that the amount of soap is excessive, drain the tank and refill.
	Blockage	If there is an obstruction in pump suction, drain and clean the wash tank. Inspect.
	Impeller	Inspect the pump impeller. If it is worn, replace it.
	Hub base	Examine the hub base to see if the wash pipe is disengaged from it. Reinstall the pipe and set screw. Note: The set screw is not on oscillating arms.
	Gauge	Examine the jet pressure gauge. If it is bad, replace it.
	Filter	Examine the filter screens. If they are dirty, remove and clean them.
Pump is gravitating. Gauge bounces up and down.	Worn wash arm	Examine the wash arm components for wear. Refer to Wash Arm System for type
	Not enough water	To determine if there is not enough water in the tank, compare the water level with the overflow tube in the machine. The machine should be filled to the top of the overflow tube. If it is not, Auto Fill time may need to be re-programmed. Another consideration is that the water supply pressure has dropped.
	Soap	If there is excessive soap in the wash tank, drain the tank. Refill with fresh water.

Troubleshooting Table for Pump Problems - All Models (cont.)

PROBLEM	LIKELY SOURCE OF PROBLEM	CORRECTIVE PROCEDURES
Pump is cavitating. Gauge bounces up and down. (can't.)	Blockage	Check the pump suction for obstruction. Drain and clean the wash tank. Inspect
	Filter	If the filter screen is dirty, remove and clean.
High jet pressure	Wash jets are clogged	Examine the wash jets to determine if they are plugged. Remove and clean the wash jets. Remove end caps from wash arms. Inspect for foreign objects and remove.

WASH ARM SYSTEM

The Wash pump system is designed to recirculate the wash water and to bring the wash pressure up to 35 psi plus, depending on the model and arm system.

Stainless Steel Ball Bearing Bayonet Hubs

This system will bring the wash pressure up to about 45 psi. As these parts wear, a large drop in pressure can occur. Check for wear by spinning the arms to ensure that they do not hit anything.

Ball Bearing Bayonet Wash Arm Parts

REF.	DESCRIPTION	COMPONENT	PART #
1	5/8" Spec Model # Complete Assembly	Arm-Bearing-Hub Base	6166
2		5/8" Bearing	3122
3		O-ring for 5/8"	3124
4	1" Spec. Model # Complete Assembly	Arm-Bearing-Hub Base	6167
5		1" Bearing	3861
6		O-ring for 1"	4404
7	Used on 5/8" or 1"	Wash Arm End Cap	2881

Bayonet Bearings End

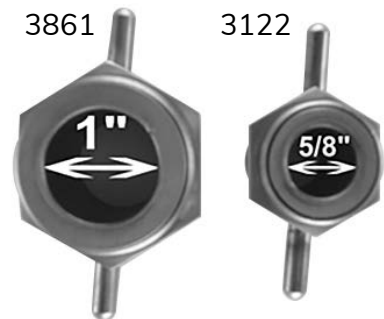

Bayonet Hub Assembly

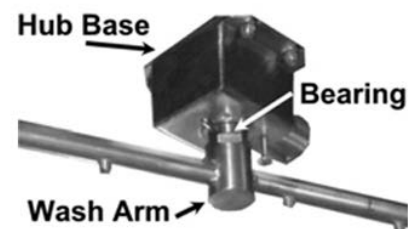

6200 Hub Base for 1" Bearing

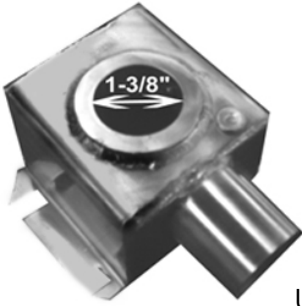

Use with 3861

6199 Hub Base for 5/8" Bearing



Use with 3122

Oscillating Arms

This system will bring the wash pressure up to about 45 psi. As these parts wear, a large drop in pressure may occur.

The system uses a motor, relay, and overload to control the delivery of water from the pump, instead of relying on water pressure to drive the arm.

Top Right View of Oscillating Arms

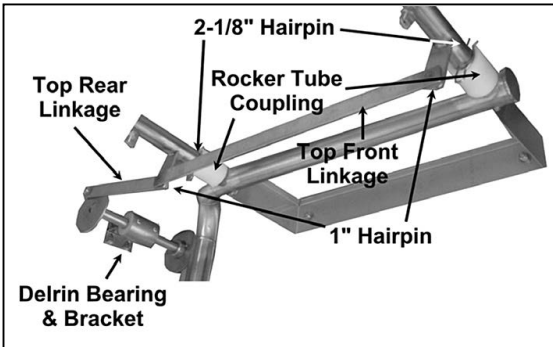

Top Right View of Oscillating Arms

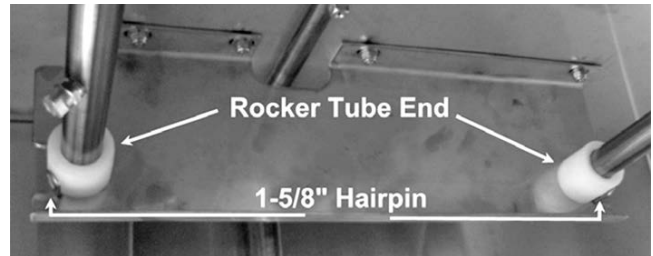

Top Left View of Oscillating Arms

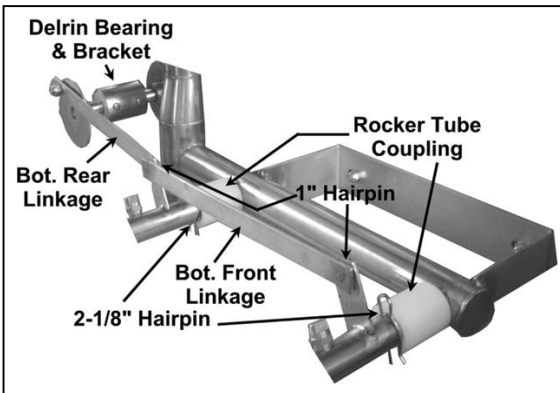

Bottom Left View of Oscillating Arms

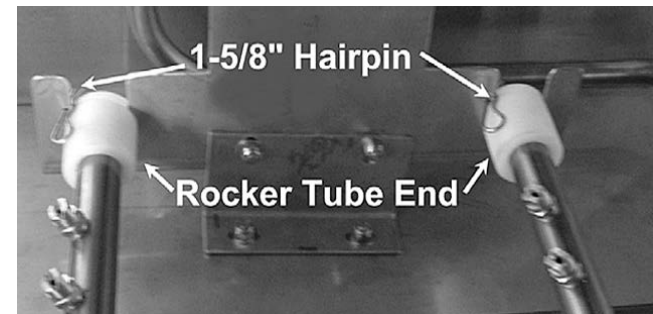

Oscillating Arms Parts Matrix

DESCRIPTION	PART #
Delrin Bearing	3842
Bracket for Delrin Bearing	6327
Top Rear Linkage	6322
Top Front Linkage	6323
Bottom Rear Linkage	6324
Bottom Front Linkage	6325
Rocker Tube Coupling	3445
Rocker Tube End	4045

DESCRIPTION	PART #
1-5/8" Hairpin	3809
2-1/8" Hairpin	0422
Drive Motor	3447
Overload	3699
Overload Holder	3698
Lower Wash Arm (No jets)	6321
Upper Wash Arm (No jets)	6320
Motor Linkage	Must specify model #

Troubleshooting Table for Oscillating Arms

PROBLEM	LIKELY SOURCE OF PROBLEM	CORRECTIVE PROCEDURES
Arms do not oscillate	Wash arm assembly	Inspect wash arm assembly inside cabinet of machine to physically see if there are obvious problems with any of the wash arm parts.
	Linkage arms	Check linkage arms to see if they are binding or have come apart. Refer to Wash Arm System: Oscillating Arms: Components.
	Voltage	With a Wash cycle chosen (wash pump motor running), check for voltage to the oscillating arm motor. Try resetting the. #11 (neutral) and #27 (bottom of motor overload) voltages should be 120 + 10 volts. This is to be checked in the electrical panel on the machine.

Troubleshooting Table for Oscillating Arms (cont.)

PROBLEM	LIKELY SOURCE OF PROBLEM	CORRECTIVE PROCEDURES
Arms do not oscillate (cont.)	Motor control relay	<p>With a Wash cycle chosen (wash pump motor running), check for voltage at the oscillating arm motor control relay.</p> <p>Terminal #2 Wire #11 (neutral) and Terminal #3 Wire #24 (hot) voltage should be 120 V ±10 V.</p> <p>This would ensure that the operation of the control is ok.</p> <p>If no voltage is found, see the wiring diagram below for further troubleshooting assistance.</p> <p>Note: Oscillating arm motor operates on 115 V.</p>

Relay is not currently in use. Oscillating Arm motor overload is powered by Wash Pump motor contactor.

Wiring Configurations

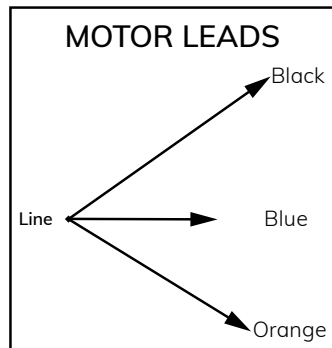
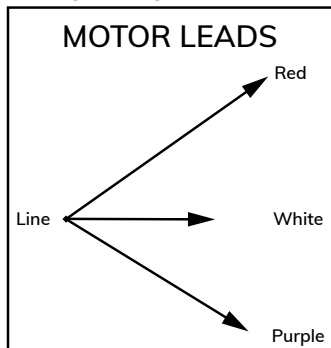

PROBLEM	LIKELY SOURCE OF PROBLEM	CORRECTIVE PROCEDURES
Motor keeps tripping the overload	High amperage	<p>Frequent tripping of the oscillating arm motor overload is an indication that the motor is operating at too high of an amperage.</p> <p>With an amp meter, check the current of the motor while in operation.</p> <p>The full load amperage is .56.</p> <p>Note: It may be necessary to disconnect the wash arm assembly from the oscillating arm motor temporarily to check the motor without a load on it.</p>

SECTION THREE

HEATING SYSTEMS

ELECTRIC HEATING

This type of system consists of one or more immersion heaters in a wash or rinse tank. Each heater ranges in size from 3 KW to 18 KW. All heaters are voltage specific. For example, 208 volt/3-phase service requires 208 volt heaters, 240 volt service, 240 volt heaters, and all other components must comply as well.

Chromalox Heaters

Phase Guide

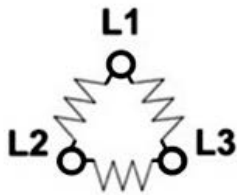

3 phase Delta

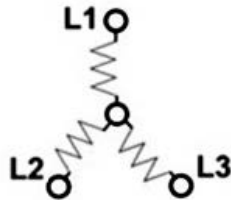

3 phase Wye

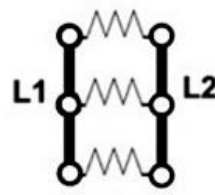

Single phase

1 ph Jumpers



3 ph Delta

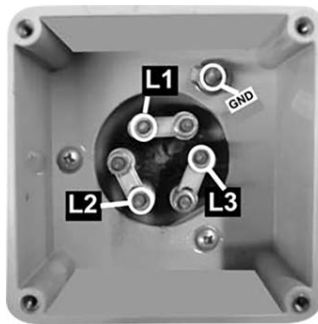

3 ph Wye



3 ph jumpers for heaters wired as Wye. The 3KW 480 volt 3 phase element is the only one wired in this format.

1981 Nut for 2" Heater



6176 S.S. Heater Washer or 2" Heater



Also use 1685 Fiber Heater Gasket

18KW Heaters

480 v. 18KW 3 ph #1913

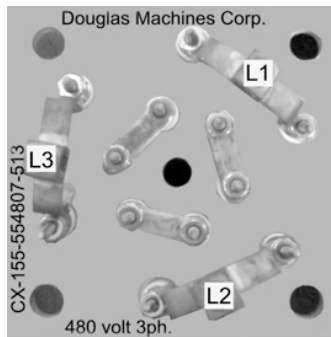

240v. 3 ph 18 KW #6225

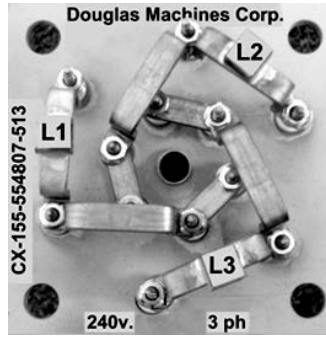

Heater orientation is very important to jumper location.

6335 S. S. Washer for 18 KW Heater

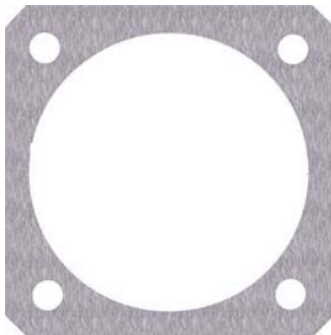

2403 18 KW Rubber Heater Gasket

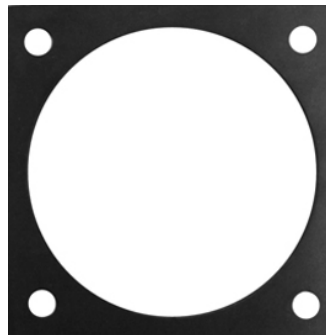

Heaters Resistance

Heaters Resistance Phase to Phase

3PH K.W.	208 PH to PH	220/240 PH to PH	380/400 PH to PH	415 PH to PH	460/480 PH to PH	575 PH to PH
3	28.8	39.5			150	
6	14.3	19.2	45.6	29.8	74	110.5
18	4.8	6.3	15.5	18.5	24.7	35

1PH K.W.	208 PH to PH	220/240 PH to PH
3	14.5	19.8
6	7	9.7
18		

Heaters Resistance Per Coil

3PH K.W.	208 Per Coil	220/240 Per Coil	380/400 Per Coil	415 Per Coil	460/480 Per Coil	575 Per Coil
3	43.5	59.2			76.8	
6	21.6	28.8	69.9		115	167
18	14.3	19	12		19	106

1PH K.W.	208 Per Coil	220/240 Per Coil
3	43.5	59.2
6	21.6	28.8
18	14.3	19

Troubleshooting Wash & Rinse

Always maintain a minimum of 2" of water above the heater element to prevent exposing the element to air.

If the heater is not properly submerged, it may overheat and shorten heater life.

Troubleshooting Table for Wash and Rinse

PROBLEM	LIKELY SOURCE OF PROBLEM	CORRECTIVE PROCEDURES
Wash water is not hot.	Power	120 V power is getting to the machine.
	Low water probe	Clean the low water probe.
	Wash circuit breaker	Reset the wash circuit breaker if tripped.
	Fuses	Check for blown fuses
	Wash thermostat	Ensure that the wash thermostat is working by checking both terminals for 120 volts. If there is no power to the supply side, it may be necessary to troubleshoot the low water circuit. Refer to Low Water Circuit: specific control type.
	Line voltage	Check to insure that the line voltage at the heater is the same as the incoming main power supply.
	Heater contactor	Check the heater contactor for voltage on both sides of the contactor.
Rinse water is not hot.	Heater delay	Ensure heater delay time is working.
	Power	Verify that power is getting to the machine.
	Rinse circuit breaker	Reset the rinse circuit breaker if tripped.
	Fuses	Check for blown fuses.
	Rinse thermostat	Ensure that the rinse thermostat is working by checking both terminals for 120 volts.
Line voltage	Check to ensure that the line voltage at the heater is the same as the incoming power supply.	

GAS HEATING

Maxon Blower System

This type of system consists of a blower mixer with an adjustable fuel orifice and blower. Air for combustion is drawn in through an adjustable air shutter. An adjustable gas orifice valve permits fuel flow to be matched to air flow for on-ratio firing.

The capacity of the blower mixer is determined by the size of the nozzle used on the system. Slight variations in combustion chamber pressure, draft conditions, or the availability of secondary air can affect ratings and performance.

The blower mixer system can be operated with natural gas or propane. This system will always be used with an immersion tube.

Blower Components

Maxon Blower System

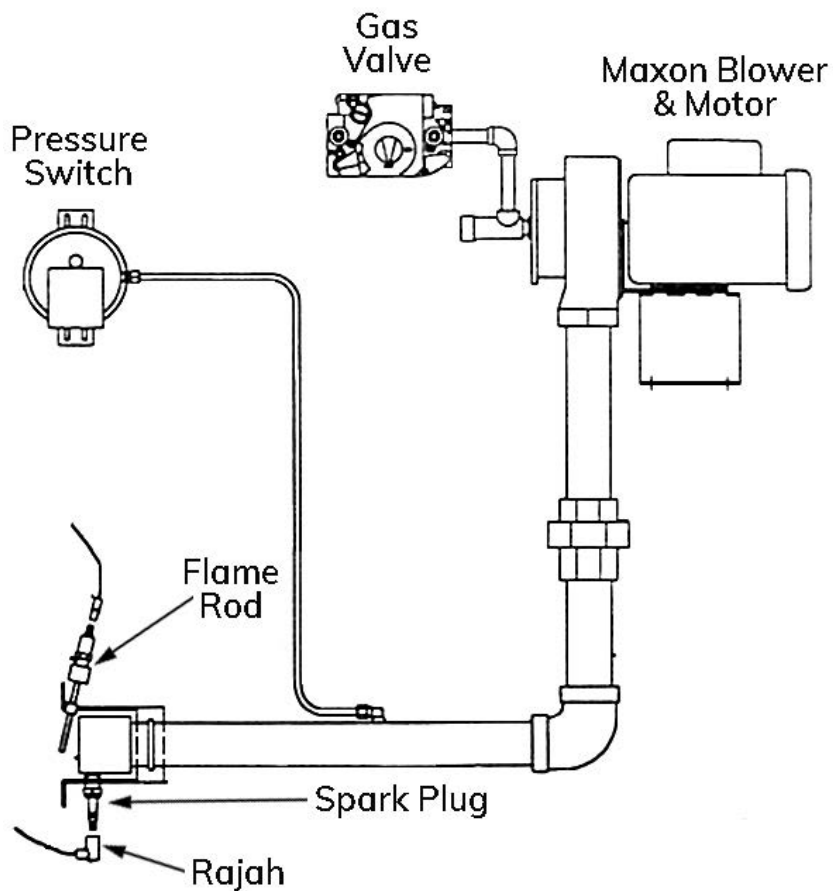

Typical layout for a Maxon gas blower assembly.

Controls

0732 Ignition Module (Old style)

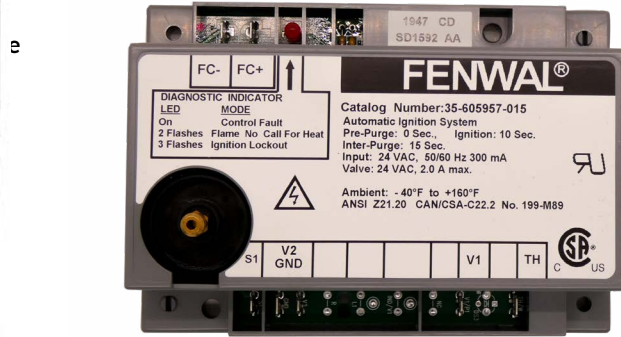
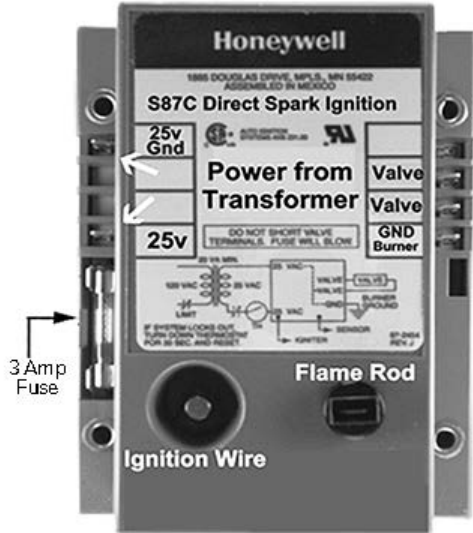

For use with the
Maxon
Blower System

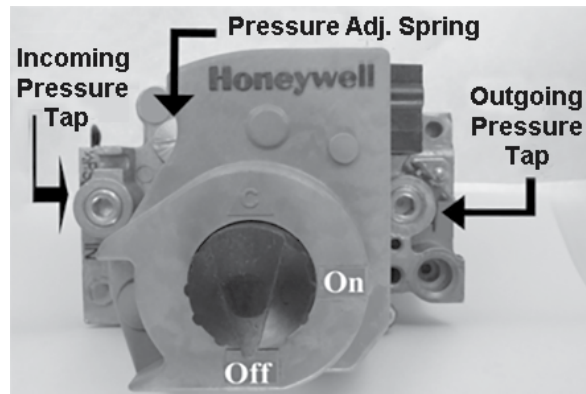
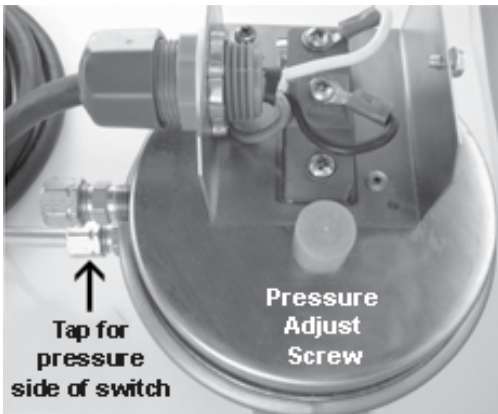
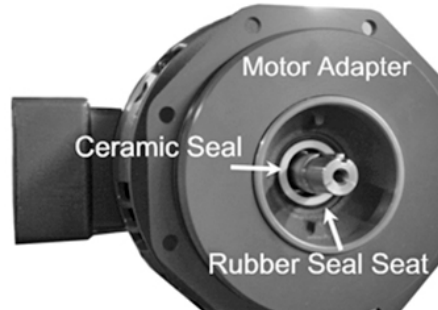
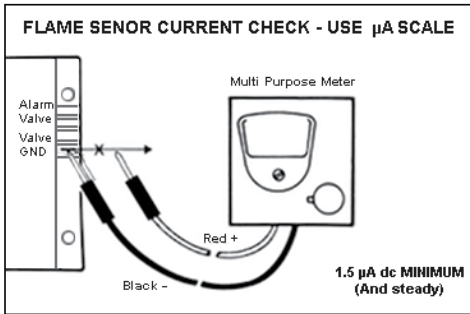

To set pressure switch, turn the screw until the flame goes out. Then, back it out one turn.

1307 for ¾" pipe or 3083 for ½" pipe.

Troubleshooting

Caution: The step up transformer in the Honeywell ignition module provides spark at 30,000 volts (open circuit). Very high voltage can cause electrical shock.

Troubleshooting Table for Maxon Blower System

PROBLEM	LIKELY SOURCE OF PROBLEM	CORRECTIVE PROCEDURES
Gas blower motor will not come on.	Thermostat	Check the respective thermostat (wash or rinse) and see if it is set at a temperature above actual tank water temperature. Thermostat may need to be adjusted to a higher setting.
	Voltage	Check to see if voltage is present at the thermostat. With thermostat set to max temperature, check for voltage at the thermostat electrical connection point. From each point to neutral, voltage should be 120 volts ±10 volts.
	Motor fan	Check to see if the fan will spin freely if done manually.
	Water level	Check to see if there is water in the tank. Low water protection component may be preventing the gas blower from operating. Low water probe / float switch in the tank may need to be cleaned. Refer to <i>Low Water Circuit: Control Type</i> .

Troubleshooting Table for Maxon Blower System

PROBLEM	LIKELY SOURCE OF PROBLEM	CORRECTIVE PROCEDURES
Gas blower motor runs and spark is present, but gas will not ignite.	Air shutter	Check to see if the air shutter needs adjustment.
	Igniter ports	Check to see if the gas needle valve needs adjustment. Refer to Gas Heating: Maxon: Components.
	Spark plug	Spark plug may be bad. Gap should be 0.080. High voltage wire may need replacement.
Gas blower motor runs and spark is present, but gas will not ignite. (cant.)	Gas lines	If machine is a new install, check to see if gas lines have been bled to let out air.
	Gas pressure	Check gas pressure to machine to see if it is too high or too low. Valve inlet: 14" W.C. Max, natural gas or propane Valve outlet: 5" natural gas; 11" propane
	Type of Gas	Check to see that the machine is set up properly for either natural gas or propane.
<p>Maxon Diagram</p> 		M-100 and M-250 unit is fired against +0.15" W.C. to +0.5" W.C. back pressure. Allow no higher back pressure.
		Make certain that the manual shutoff valve in the supply line and the gas cock knob on the combination gas control valve are open.
		Check spark plug alignment with igniter port in burner nozzle.

Troubleshooting Table for Maxon Blower System (cont.)

PROBLEM	LIKELY SOURCE OF PROBLEM	CORRECTIVE PROCEDURES
---------	--------------------------	-----------------------

Set nozzle so that spark plug is at 1 or 11 o'clock.

1. Ensure that the open end of the spark igniter gap faces the igniter port.
2. Before installing the spark igniter, make a mark on the side of it in relationship with the open gap side so that, when tightened down into the nozzle, the mark on the igniter faces the igniter port.

Gas blower motor runs, spark is present, and gas ignites but flame will not stay on.	Flame rod	<p>Check flame rod placement in conjunction with flame.</p> <p>Rod should be contacting the outer portion of the flame.</p> <p>Ensure that the rod does not contact the machine chassis.</p>
--------------------------------------------------------------------------------------	-----------	----------------------------------------------------------------------------------------------------------------------------------------------------------------------------------------------

Carlin Gas Burner Control

Model 60200FR Gas Burner Primary Control

Installation and Operating Instructions

For Use By Qualified Service Technicians Only



- On-Board LCD Screen
- Fully Programmable Settings
- 32 Cycle Fault History
- Alarm Contacts
- Serviceman Reset Protection
- Blocked Vent Protection
- Provides Flame Signal in Microamps
- Low Voltage Terminals

It is important that the installation of the oil burner, piping and fittings, safety devices, controls, electrical wiring and equipment be done in accordance with national and/or local regulations of the authorities having jurisdiction over such installation.

Power input (red/white wire).....	120 VAC, 60 HZ, 9 VA
Limit circuit input (black wire)	120 VAC, 60 HZ
Motor load (orange wire).....	10 FLA / 60 LRA (reduce by valve load)
Ignitor load (blue wire).....	120 VAC, 60 HZ, 500 VA
Valve load (violet wire).....	120 VAC, 60 HZ, 2A
Auxiliary.....	120 VAC, 1 amp
Operating voltage.....	120 VAC - 132 VAC
Alarm contacts (dry contacts).....	24V, AC/DC, 2A
Operating temperature limits.....	+32°F to +140°F
Thermostat.....	24 VAC, 0.1A
Blocked Vent.....	12 VDC, 2mA
CO.....	12 VDC, 2mA
Agencies.....	UL recognized (US & Canada)

FROZEN PIPES/WATER DAMAGE

This is not a freeze protection device. Suitable freeze protection monitoring or other precautions are recommended to protect against ruptured pipes/water damage caused by fuel outage, safety related fault conditions or equipment failure.

WARNINGS

1. **Warning** – Do not attempt to confirm combustion simply by inspecting the flame visually. You must use combustion test instruments. Failure to properly verify/adjust combustion could allow unsafe operation of the burner, resulting in severe personal injury, death or substantial property damage. Refer to the burner manual for proper setup instructions.
2. **Warning** – Never test an ignitor by placing a screwdriver (or other metallic object) across the high voltage clips. Check ignitors only by observing spark at appliance ignition electrodes, with fuel supply OFF. Using any other method could cause ignitor damage and severe personal injury.
3. **Danger – Fire, explosion, or carbon monoxide hazard.** Water damage can lead to unreliable operation or cause the control to malfunction which could lead to severe personal injury or death. Do not install the control module where it can get wet. Always replace the control if it gets wet or if it has any signs of water residue.
4. **Warning – Electrical shock hazard.** To prevent electrical shock, death, or equipment damage, disconnect power supply before installing or servicing control. Only qualified personnel may install or service this control in accordance with local codes and ordinances. Read instructions completely before proceeding.
5. **Warning – Electrical shock hazard.** The ignition circuit of the control can produce over 10,000 volts which can cause severe injury or death.
6. **Warning – Frozen pipes/water damage.** This is not a freeze protection device. Central heating systems are prone to shut down as a result of power or fuel outages, safety related fault conditions or equipment failure. Installation of freeze protection monitoring or other precautions are recommended for unattended dwellings in climates subject to sustain below-freezing temperatures.
7. **Warning** – All work must be performed by a qualified and licensed professional in accordance with all applicable codes and ordinances.
8. **Notice** – Read these instructions completely before proceeding with the installation.
9. **Notice** – Retain these instructions for future reference.
10. **Notice** – All wiring must comply with the National Electric Code or any other state or local codes or regulations.
11. **Danger – Carbon Monoxide Hazard.** Improper application or use can result in dangerous flue products, such as carbon monoxide, which can escape into the living space causing severe injury or death. All venting must be checked for proper operation before allowing the burner to run.

Hazard Definitions

The following defined terms are used throughout this manual to bring attention to the presence of hazards of various risk levels or to important information concerning the life of the product.

DANGER

Indicates presence of hazards that will cause severe personal injury, death or substantial property damage.

CAUTION

Indicates presence of hazards that will cause minor personal injury or property damage.

WARNING

Indicates presence of hazards that will cause severe personal injury, death or substantial property damage.

NOTICE

Indicates special instructions on installation, operation or maintenance that are important but not related to personal injury or property damage.

Installing

WARNING The 60200FR control must be installed and serviced only by a qualified service technician.

Always disconnect power source before wiring to avoid electrical shock or damage to the control. All wiring must comply with applicable codes and ordinances.

Mounting

The control may be mounted on a 4" x 4" junction box in any convenient location on the burner, furnace or wall. The location must not exceed the ambient temperature limit, 140°F.

Field Wiring

Wiring must comply with local and national electrical codes, and with the wiring diagram.

WARNING Do not connect an external voltage to the thermostat terminals T1 and T2. This will damage the control and may result in a *dangerous* operating condition.

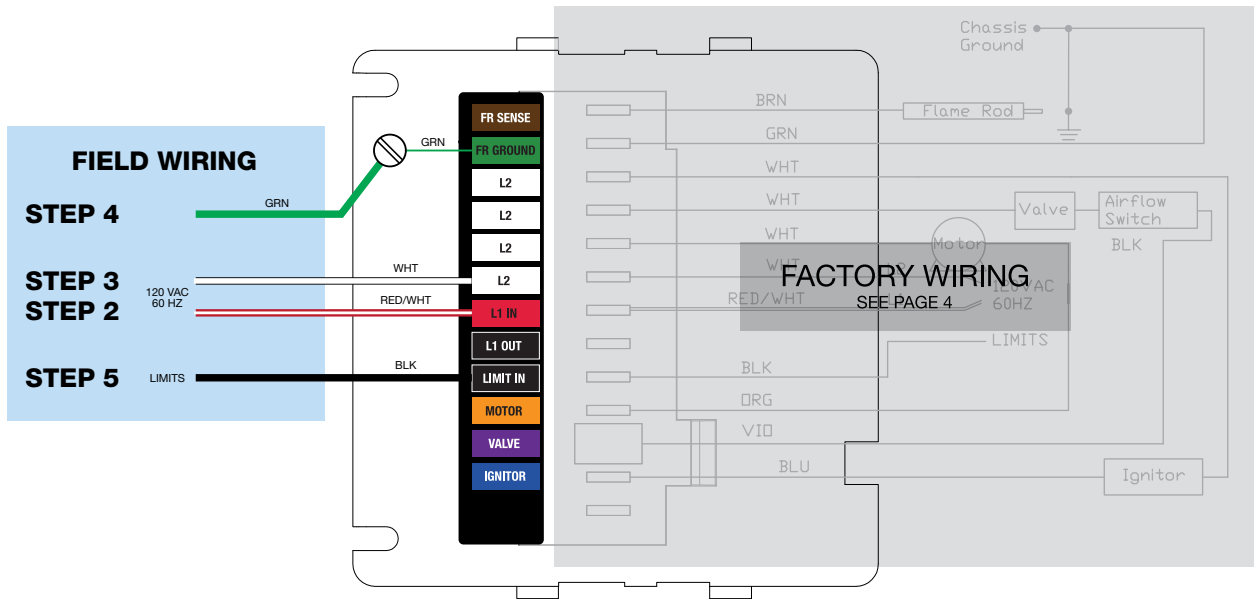

The burner (motor, valve, ignitor, etc.) is prewired at the factory. The following steps are for field wiring.

Step 1 Remove the 60200FR control from the electrical junction box to access the terminal strip located on the bottom of the control.

Step 2 Connect incoming, 120 VAC Hot from the boiler/furnace service switch to the red wire with white stripe attached to (L1 IN). This will supply constant power to the control for post purge (motor delay off) operation and display functionality when in standby mode. Note: If a constant 120 VAC power source from the service switch is not available, connect the red/white wire attached to (L1 IN) to the black wire attached to (LIMIT IN).

NOTE: Check polarity carefully. If hot and neutral wires are reversed at appliance power source, the control will go to Lockout on flame failure.

Step 3 Connect 120 VAC Neutral to the white wire attached to (L2).

Step 4 Connect the ground wire to the green ground screw inside the junction box. Connect the “FR Ground Terminal” to the green ground screw inside the junction box. Confirm that the junction box is connected to earth ground. Important: If the ground wire is not secured, the control will not sense flame properly resulting in nuisance lockouts.

Step 5 Connect the boiler/furnace limit output to the black wire connected to (LIMIT IN).

Replacing the old 60200FR control

1. Remove old control from J-Box
2. Remove Rajah connector from flame rod wire
3. Wire nut the existing wires to the spade provided wires and connect to control

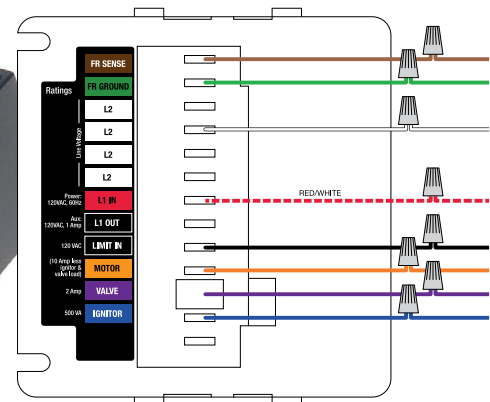

Wiring

Wiring must comply with local and national electrical codes, and with the wiring diagram.

Commercial Gas Train 120V FACTORY WIRING

FOR FIELD WIRING SEE PAGE 3

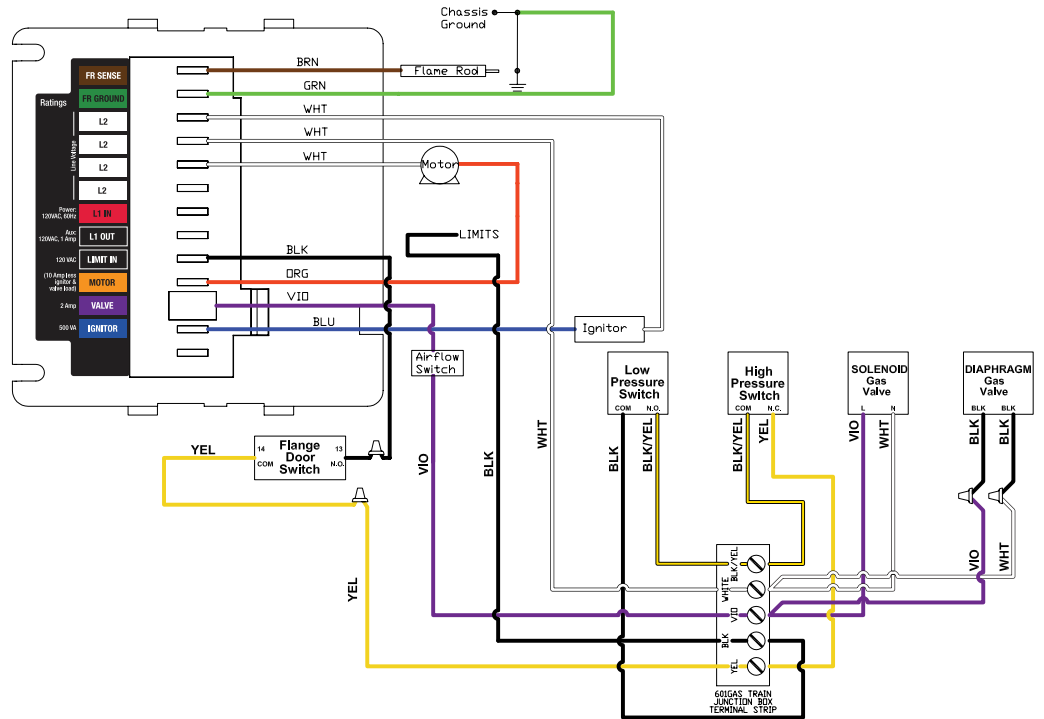

EZGas Pro 24V FACTORY WIRING

FOR FIELD WIRING SEE PAGE 3

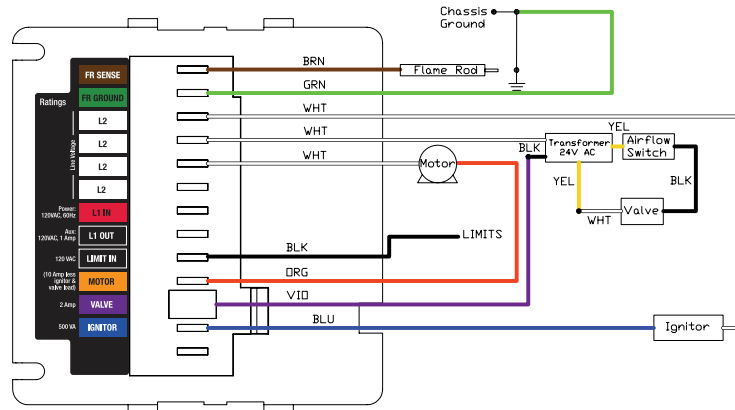

EZGas 120V FACTORY WIRING

FOR FIELD WIRING SEE PAGE 3

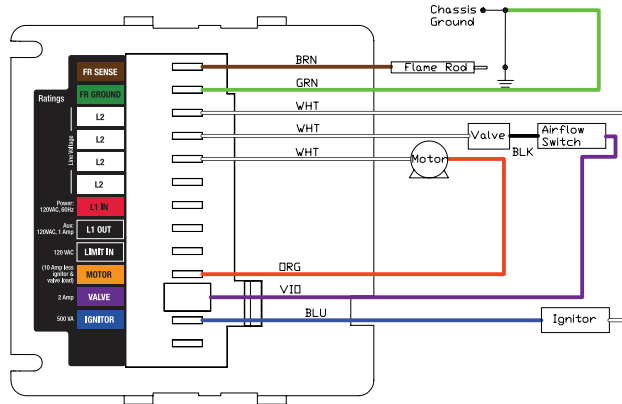

Low Voltage Wiring

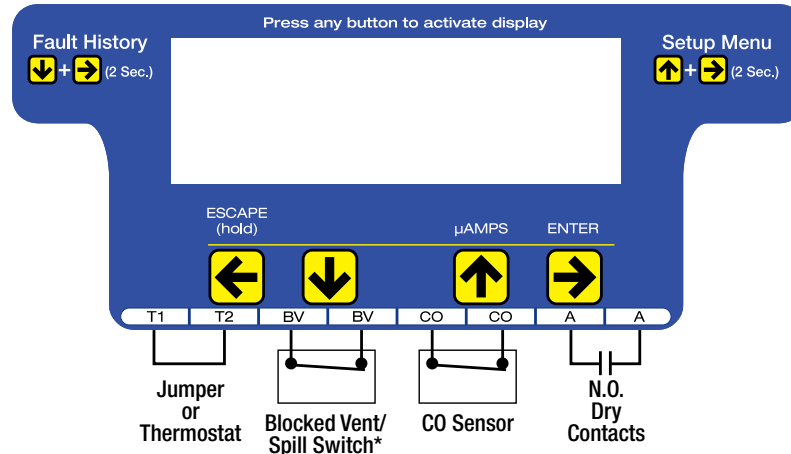

***Blocked Vent/Spill Switch Operation:** During each run cycle, the BV contacts will be checked beginning 30 seconds after ignition. If the BV contacts open (indicating the spill switch has detected a blocked vent), the control will shut down the burner. The control will either recycle the burner or will go immediately into Lockout dependent on the Allowed Recycle setting. The spill switch must be closed within 2 seconds on a call for heat. If not, it will retry 2 times before control goes into Lockout.

NOTE: If using a manual reset blocked vent spill switch, the control will lock out with the display reading BV Switch Open.

WARNING Do not start the burner if the combustion chamber contains gas.

View or Change Control Settings

NOTE: The settings mode cannot be accessed during a run cycle, the burner must be in standby mode (or Lockout) to enter setup.

To enter the Settings Mode: Press the \uparrow and \rightarrow buttons simultaneously for 2 seconds. The display will show –

```
Settings Press  $\rightarrow$ 
To Exit Hold  $\leftarrow$ 
```

To View Current Settings: Press the \rightarrow button to scroll through all Setting Modes (see table at the top of page 5 for Setting Mode options). The second line of the screen will display the current setting for each Setting Mode –

```
Pre-Purge
  30 Seconds
```

Pressing the \rightarrow button again will leave the setting as is and move to the next option –



```
Trial for Ign
  4 Seconds
```

To Change a Setting: Scroll to the desired Setting Mode option using the \rightarrow button (as described in table on page 5), then press the \uparrow or \downarrow button to scroll through the available Settings. When the desired setting is displayed on the screen press the \rightarrow / ENTER button. The display will briefly indicate that the new setting has been “Entered” and the new setting will replace the previous setting on the second line of the screen. Continue pressing the \rightarrow button to view the current setting for all options or \downarrow button to make any desired changes.

```
Trial for Ign
  6 Seconds
```

To Exit the Setup Menu: Press the \leftarrow / ESCAPE button for 3 seconds. **NOTE:** The control will automatically exit the Setup menu after 30 seconds of inactivity or by a call for heat.

AVAILABLE SETTINGS

PRESS THE  BUTTON TO VIEW DIFFERENT SETTING MODES							
SETTING MODE OPTIONS	Pre-Purge [†]	Trial for Ignition	Post-Purge	Allowed Recycles ^{††}	TT Jumpered Internal ^{**}	Clear Fault History	Restore Factory Defaults
PRESS THE   BUTTONS TO CHANGE SETTINGS	0 Sec	4 Sec	0 Sec	None*	Yes	Yes	Yes
	10 Sec	6 Sec	10 Sec	1	No	No	No
	30 Sec		15 Sec	3			
	90 Sec		30 Sec				
			60 Sec				
		2 min					

Shaded box = default setting.

*MA Code ("N" models) are non-recycling and will lock out on flame failure.

**Changing this setting to 'Yes', with limits powered will exit Settings mode and result in immediate 'Call For Heat'.

†If flame is sensed during Pre-Purge, control will go to Lockout immediately – except when Pre-Purge is set to 0 Sec.

††If TFI fails after first recycle, control will lockout, regardless of "Allowed Recycles" setting.

Setup Menu Definitions

- **Pre-Purge:** Time period motor and ignitor are on prior to Trial for Ignition. **Note:** If flame is sensed during Pre-Purge, control will go to Lockout immediately.
- **Trial for Ignition:** Flame-establishing period during ignition. If flame is not established, the control will recycle. The next cycle will be a set 60 second Pre-Purge. If TFI fails on the next cycle, control will go to Lockout.
- **Post-Purge:** Time period the motor is on after the Call for Heat is satisfied to allow for evacuation of combustion gases. A call for heat during Post-Purge will result in a recycle.
- **Allowed Recycles:** Number of Recycles allowed during a single Call for Heat prior to Lockout.
- **TT Jumpered Internal:** Allows TT to be "jumpered" by software program.
- **Clear Fault History:** Allows all prior burner fault conditions stored in control to be cleared.
- **Restore Factory Defaults:** Allows all factory defaults to be restored in control (refer to settings shaded in gray in the table above). Will reset and reboot control .

Operating Sequence

With power to the control and the gas valve open, set thermostat (and limit) to call for heat. **NOTE:** The thermostat circuit must be closed and power must be coming to black wire from limit circuit.

During **Pre-Purge**, the motor starts.

```
Pre-Purge
      XX Sec
```

Following **Pre-Purge**, the control advances to a 3 second **Pre-Ignition**

```
Pre-Ignition
      XX Sec
```

During **Pre-Ignition**, the ignitor turns on and enters **Trial for Ignition**.

```
Trial for Ign
      XX Sec
```

During **Trial for Ignition**, the gas valve opens. When flame is detected, the screen will briefly display "Flame Detected" and then proceeds to **Burner Running**

```
Burner Running
      59 Sec
```

When the Call for Heat ends (or a limit control interrupts the burner circuit), the gas valve will turn off. The motor remains on for the **Post-Purge** period. When the **Post-Purge** timer expires, the control returns to **Standby** mode awaiting the next call for heat.

```
Post-Purge
      XX Sec
```

```
Standby      59 Sec
No Call for Heat
```

SEE STATUS ICONS – PAGE 8

Fault History

The 60200FR stores information from the last 32 cycles in which a fault condition occurred. To Enter the Fault History , simultaneously press and hold the and buttons for 2 seconds. The display below will appear –



Press the button to scroll through the history of fault conditions. Fault 1 is the most recent cycle in which a fault occurred. To view faults experienced in earlier run cycles, continue to press the button. The control will display Fault 2 followed by Fault 3, etc.

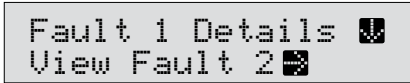

To view the details of any fault (ex. Fault 1 in the screen above), press the button to see the Fault Message.



Press the button again to determine how many cycles ago the fault occurred.



Press the button again to determine if the fault resulted in a Lockout or a recycle.

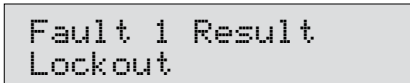

Press the button again to examine the Microamps at the time of the fault.



Continue pressing the button to examine the following information recorded during the fault cycle.

- Line Voltage
- Motor Amps (OK or Low)
- Ignitor Amps (OK or Low)
- Valve Amps (OK or Low)
- Recycle (Yes or No)
- Burn Time
- Flame Delay

On any fault detail screen listed above, the button can be pressed to view the same data in the previous fault cycle. For example, if in Fault 1 (the most recent fault), the Ignitor Amps were low, by pressing the button, the Ignitor Amps in Fault 2 (the previous fault cycle) will be displayed.

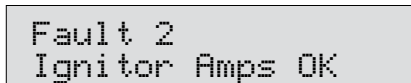

To Exit Fault History: Press and hold the / **ESCAPE** button for 3 seconds at any time.

Total/Run History

In addition to the Fault History (left), the 60200FR also logs the total run history of the control. To enter this menu, simultaneously press the and buttons for 3 seconds. The display below will appear.



To Exit Total History: Press and hold the / **ESCAPE** button for 3 seconds at any time.

Press button to scroll through the history which includes:

- Total On Time
- Total Burn Time
- Total Burner Run Cycles
- Faults Cleared (cycles ago)
- Max Line Volts
- Min Line Volts
- Total Recycles

FAULT HISTORY

NOTE: Fault information in chart is representation only.

PRESS THE BUTTON TO VIEW NEXT FAULT						
	FAULT 1	FAULT 2	FAULT 3	FAULT 4	FAULT 5	
Message	No Flame ck vlv	No Flame ck MTR	No Flame ck IGN	No Flame ck vlv	No Flame ck vlv	
Cycles Ago	2	3	4	5	6	
Result	Lockout	Lockout	Lockout	Lockout	Lockout	
µAmps	0.1	0.1	0.1	0.1	0.1	
Line Volts	114	114	114	114	114	
Motor Amps	OK	Low	OK	OK	OK	
Ignitor Amps	OK	OK	Low	OK	OK	
Valve Amps	Low	OK	OK	Low	Low	
Recycle Y/N	No	No	No	No	No	
Burn Time	5 sec	5 sec	5 sec	5 sec	5 sec	
Flame Delay	4 sec	4 sec	4 sec	4 sec	4 sec	

PRESS THE

BUTTONS TO VIEW FAULT DETAILS

Status Icons



Status Icons will appear at the top of the 60200FR display to indicate the control's current operating condition.

- POWER** Indicates that the control is powered (flashes if voltage is too low or too high)
- HV LIM** Indicates that the burner limit circuit is powered.
- TT** Displayed when the TT terminals are physically jumpered, jumpered in the set-up menu, or when thermostat is calling for heat.

- BV** Monitors the BV contacts where a Blocked Vent Switch (Spill Switch) is connected. (Flashes if the Spill Switch contacts are open – indicating that the vent is blocked). See Blocked Vent Operation below for more information.
- FLAME** Indicates the control is sensing flame
- FAULT** Flashes in unison with other status icons indicating a problem exists in that area
- MOTOR** Indicates that the motor is energized (flashes if motor not detected)
- IGNITOR** Indicates that the ignitor is energized (flashes if ignitor not detected)
- VALVE** Indicates that the gas valve is energized (on entry to pump prime will flash if not detected)

Service and Troubleshooting

Last Fault Display: When the control is reset from a Lockout condition, if the burner resumes normal operation, the screen will toggle the last fault and its cause for five days (longer duration if control is not wired for constant power). This feature is designed to allow the service technician to easily see what caused the condition in the event the homeowner reset the control prior to their arrival. The screen will alternate between displaying what the last fault was and displaying how to clear the message **hold ESC for 3 seconds**.



Toggle

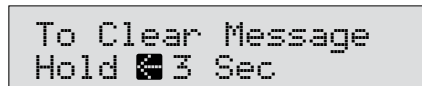

Display Voltage and Current: Press $\uparrow + \downarrow$ for 3 seconds to display real time voltage and current.



Lockout: If Lockout occurs, the screen turns on, the fault icon flashes and a fault message is displayed on the screen. **To Reset** Push in and hold the red **Reset** button for 1 second, then release. **NOTE:** Recycling power to the control will not reset it from it from a Lockout condition.

Two fault conditions result in an immediate Lockout. These include; Flame detected during pre-purge and flame failure during Trial for Ignition (during second cycle, following recycle). All other faults will result in a Recycle (unless the Allowed Recycles is set to 'None' in the Set-up Menu). A **Recycle** results in the burner shutting down for 60 seconds then resuming operation in Standby (if there is no Call for Heat) or initiating the Operating Sequence above (if there is a Call for Heat).

Latch-up: If the control locks out 3 times during a single Call for Heat, Latch-Up will be displayed on screen.

To Reset the control after latch-up, press and hold the red Reset button for 30 seconds. **WARNING: Only a qualified**

service technician should attempt to reset the control after latch-up. The problem that caused the repeat lockouts must be corrected before returning the burner to normal operation. NOTE: Recycling power to the control will not reset it from it from a latch-up condition.

Burner will not fire

- Valve lead voltage on too early. Correct bad connection.
- Motor relay welded. If valve has no voltage, and line voltage is okay (102 - 132 VAC), the issue is a welded motor relay. Replace the control.
- Motor current less than 0.2 Amps.

Blocked vent – not recycling:

- Recycle only works on non-manual reset vent switch

Repeated flame failures

Check for:

- Excessive airflow or draft causing flame to leave burner head- check for proper air band setting and draft.
- Excessive back pressure causing flame to be erratic – check appliance and flue for sooting/plugging.
- “Flame rod shorted” message in Lockout – defective flame rod assembly.

Control locks out at end of TFI

- No fuel to burner – check fuel supply lines.
- Shorted electrodes – inspect for cracked porcelain and replace as needed.
- Airflow too high – check air band setting.
- Ignitor module defective – replace if no spark.
- Check wiring connections.
- Flame rod shorted to ground or defective.
- FAIL TFI - RECYCLE: Control Attempted TFI, failed, recycled, and failed for a 2nd cycle.

Control remains in Standby during a call for heat

The 60200FR control needs to have an input voltage of 102 VAC to 132 VAC to function properly. When voltage to the control is out of range, the control will revert to or remain in standby mode until the voltage is restored to an acceptable operating level.

TECH SUPPORT HOTLINE 800-989-2275

Carlin[®]
Combustion Technology

Carlin Combustion Technology

126 Bailey Road North Haven, CT 06473 Phone 203-680-9401 Fax 203-764-1714
e-mail us at: info@carlincombustion.com www.carlincombustion.com

Carlin Gas Burner

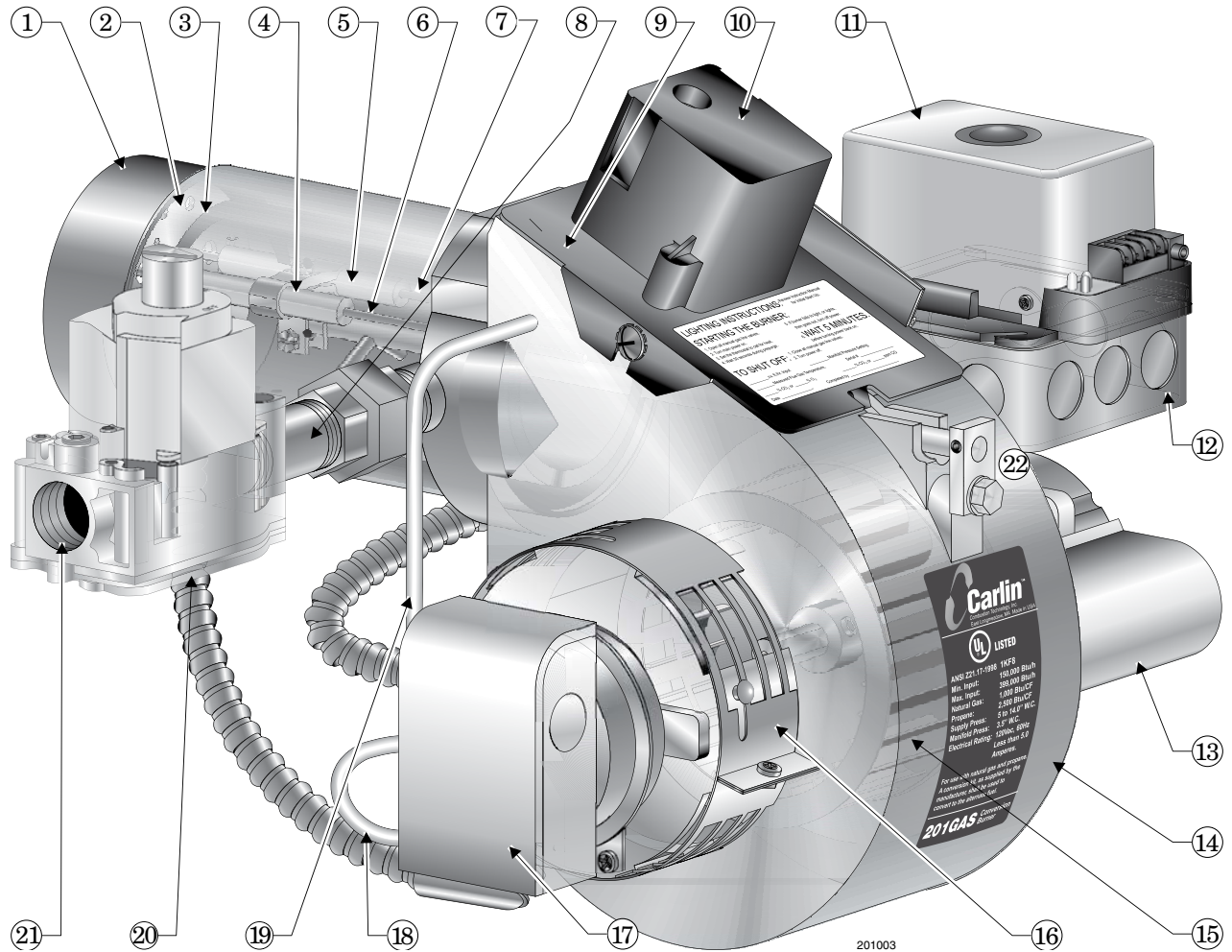

- | | |
|-------------------------------------------------------------------------------------------------------------------------------------------------------------------|----------------------------------------------------------------------------------------------------------------------------|
| 1 Air tube (flange omitted for clarity), with powder coat paint finish | 12 Burner junction box |
| 2 Diffuser plate (hole or slot pattern) | 13 Motor (with permanently-lubricated bearings and thermal over-load protection) |
| 3 Gas manifold (concentric cylinders swaged and welded at ends)
— Gas manifold delivers gas to gas openings on inner wall of manifold near the diffuser plate. | 14 Blower housing (cast aluminum), with powder coat paint finish |
| 4 Ignitor electrode insulator | 15 Blower wheel |
| 5 Flame rod insulator | 16 Air band — Only a single adjustment required for setting combustion air; see page 7 for starting setting based on input |
| 6 Ignitor electrode | 17 Airflow proving switch — Prevents burner from firing if air is not moving |
| 7 Flame rod electrode | 18 Airflow proving switch sensing line (aluminum) — blower inlet |
| 8 Gas orifice nipple — see pages 7 and 8 for orifice sizing requirements | 19 Airflow proving switch sensing line (aluminum) — blower outlet |
| 9 Hinged cover plate (for access to blower wheel & electrodes) | 20 Combination gas valve (with integral gas pressure regulation — set for 3½" w.c. outlet pressure) |
| 10 Ignitor (Carlin Model 41800 solid state electronic ignitor — 9,000 volts, continuous duty rated) | 21 Gas supply entrance — ¼" NPT; 5" w.c. min; 14" w.c. max |
| 11 Primary control — Carlin Model 60200FR microprocessor-based interrupted ignition flame supervisory control (flame rectification) | 22 Flame rod/ignition electrode assembly yoke |

Where appliance instructions differ from this manual, follow the appliance instructions.

7. Troubleshooting

Problem	Possible cause	Corrective action
WARNING		These procedures must only be performed by a qualified service technician. Use care when performing tests on electrically or mechanically live parts. Disconnect power to burner/appliance and close main manual gas valve when removing components for service. Failure to comply could result in severe personal injury, death or substantial property damage.
Burner motor will not start	120 VAC power circuits	Check voltage and polarity at entrance to appliance and burner. Check fuse or breaker protecting circuit. Check appliance limit circuit — are controls calling for heat? Check electrical connections.
	Primary control is in Lockout	Red LED will be on. Press the reset button for 1 second. If red LED comes back on in a couple of seconds, there could be voltage present to the gas valve or the motor relay contacts could be stuck in the closed position. The Safety Monitoring Circuit causes lockout if this occurs. If there is no voltage present at the gas valve (using a voltmeter), replace the control. If there is voltage at the gas valve, check all wiring for accuracy. Replace the control if the 60200FR gas valve wire shows 120 VAC when disconnected from the burner wiring.
	Primary control is in Latch-up	Red and amber LED's will both be on. See page 12 for procedure to handle this condition. When resetting control from Latch-up, be sure to investigate what caused the repeated failures. Correct the condition.
	Incorrect wiring	Check wiring against appliance and burner wiring diagrams. Verify all connections are secure.
	Defective motor	Remove motor leads from junction box and apply power directly. If motor fails to operate, then replace.
	Defective primary control	If control receives power to both the black and red/white wires, but doesn't start the motor, the control may be defective. Replace control.
Repeated flame failures — burner won't light	Airflow too high	Check air band setting against Table 1, page 7. Reposition to correct setting if necessary.
	Gas orifice wrong	Check gas orifice size. See pages 7 and 8 for procedure.
	Wrong manifold pressure	Check combination gas valve outlet pressure — should be between 3.2 and 3.8 inches w.c. unless specified.
	No gas supply to combination gas valve	Check main manual gas valve — might be closed. Attach manometer to combination gas valve supply pressure tapping and check pressure. If no pressure, trace gas line to find why no gas is available.
	Gas valve not opening	Check gas supply pressure to combination gas valve. Pressure in excess of 14 inches w.c. will cause valve to lockup. Check voltage to gas valve. Is gas valve receiving 120 VAC? If gas valve is receiving 120 VAC and not opening, and gas supply pressure is below 14 inches w.c., replace gas valve.
	Airflow switch	Check electrical connections and sensing connections to airflow switch. If blower operates, check across switch to see if it makes. If switch is correctly connected, but won't close, replace airflow switch. To verify switch is receiving signal, connect a manometer across the sensing lines.
	Primary control defective	Check voltage to gas valve during TFI. If no voltage to valve, replace control.

Infrared Heating System

This type of system consists of a normally aspirated burner with a venturi where air and gas are mixed and forced into the burner chamber. A wash or rinse tank may contain one or more burners per tank, depending on the BTU's that are necessary to heat the tank.

The nozzle and physical size of the burner determine its BTU capacity and type of gas.

An infrared burner can be operated with natural gas or propane.

IR Spark Plug Flame Rod Gap Setting - Old Style



Micro Amps

IR Spark Plug Flame Rod Gap Setting - New Style



3/16" Between both rods and screen

1307 for 3/4" pipe or 3083 for 1/2" pipe

Controls

2075 Ignition Module (Old style)

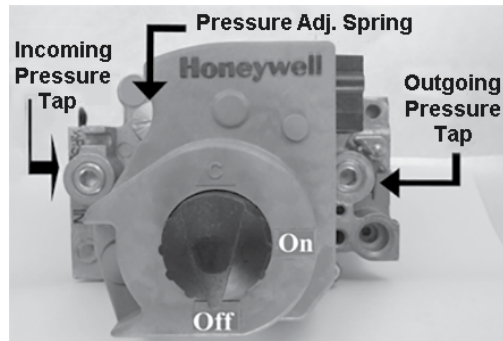
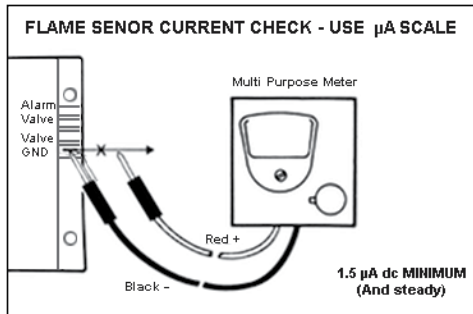
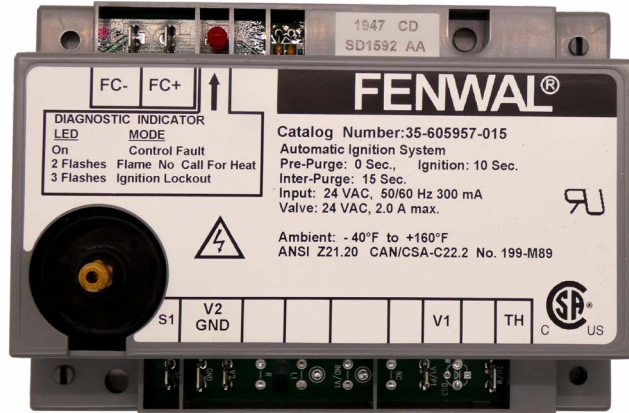

Troubleshooting I.R. Burners

Before parts and pressures can be determined, the source of the gas supply must be located.

Determining Gas Type

Caution: The step-up transformer in the Honeywell ignition module provides spark at 30,000 volts (open circuit). This is a very high voltage and electrical shock can result.

Troubleshooting Table for Infrared Burners (cont.)

UTILITY SUPPLY			
Gas Type	Minimum	Maximum	Valve Outlet
Natural	6" W.C.	14" W.C.	5"
Propane	11" W.C.	14" W.C.	11"

Manometers may be connected to inlet or output pressure taps on gas control.

Normal Operation

1. When the burner lights, a flame-sensing circuit is completed through the flame to the spark rod or flame rod. This current flow sets the safety lockout timer to the reset (normal) condition and interrupts the spark ignition circuit.
2. Note that, if the current flow is interrupted, such as when a flame-out condition occurs, the 10-second (7 seconds in Canada) trial-for-ignition begins again.
3. Note that if the burner does not relight, the ignition module will go into safety lockout condition (Fenwal - After three tries).
4. At this point, the thermostat will have to be reset to restart the system, or the power may be cycled off and on.

Note: The burner igniter rod serves a dual purpose. It is a spark igniter rod and also a flame sensing rod. Do not try to bend this rod. The porcelain insulator may become damaged and would have to be replaced.

Troubleshooting Table for Infrared Burners

PROBLEM	LIKELY SOURCE OF PROBLEM	CORRECTIVE PROCEDURES
No spark at igniter rod.	Gap	Check the gap at the end of the igniter rod to the fixed rod with 90° bend. Gap should be about 1/8" – 1/4". Ground rod should be down on screen with igniter above it.
	Igniter rod	Check that igniter rod is not directly contacting either the fixed rod or the burner itself.

Troubleshooting Table for Infrared Burners (cont.)

PROBLEM	LIKELY SOURCE OF PROBLEM	CORRECTIVE PROCEDURES
	Low water	Confirm that water is in the tank. The low water protection component may be preventing the burner from operating. The low water probe / float switch may not be sensing water level and may need to be cleaned. Refer to <i>Low Water Circuit: Specific Control Type</i> .
	Lockout	The system may have gone into lockout. Cycle power by turning off thermostat or power supply off and on.
	Thermostat	Ensure that the thermostat is working by checking both terminals for 120 V. If there is no power to the supply side, troubleshoot the low water circuit.
No spark at igniter rod. (cont.)	Ignition	Check the ignition module for blown fuse. If fuse keeps blowing, check to see if the gas valve may be bad.
	24 volt supply	Check for 24 volt supply to the ignition module from the transformer.

Troubleshooting Table for Infrared Burners (cont.)

PROBLEM	LIKELY SOURCE OF PROBLEM	CORRECTIVE PROCEDURES	
Burner lights, but it will not stay on.	Igniter/ Flame rod	<p>Check the igniter/flame rod at end of rod to see if it is contacting the fixed rod or screen when the screen rises with heat from the burner.</p> <p>The ignition module will go into lockout if the flame rod contacts any part of the machine.</p>	
	Type of gas	Confirm whether the machine has been set up for the correct type of gas: natural or propane.	
	Flue draft	<p>Check the draft on the flue, measured at the top of the machine where the duct connects.</p> <p>The draft should be negative 0.045" W.C.</p> <p>A draft inducer or barometric dampener or both may be needed.</p>	
	Gas pressure	Check the gas pressure at the valve.	
		Inlet	14" W.C. max, natural or propane
		Outlet 5" W.C.	Natural
Outlet 11" W.C.		Propane	
A minimum of 1" differential is needed across the gas valve.			
Flame rod	<p>Check the flame rod micro-amps.</p> <p>The flame rod must be close enough to the flame of the burner so that it can sense the ions in the flame.</p>		
Burner lights, but it will not stay on. (cont.)	Gas supply	<p>Confirm that an adequate supply of gas is getting to the machine.</p> <p>It may be necessary to consult a plumber or someone from the utility company to confirm that the building has a large enough supply to satisfy all gas consuming appliances.</p> <p>There is a label on the Douglas machine that indicates the total BTU rating of the entire machine.</p>	

PROBLEM	LIKELY SOURCE OF PROBLEM	CORRECTIVE PROCEDURES
Burner lights in venturi.	Gap at spark/flame	<p>Check the gap at the spark/flame rod.</p> <p>If the gap is not correct and the spark is erratic, gas can build up in the burner box and possibly ignite in venturi.</p>
	Gas nozzle	<p>Check the gas nozzle alignment with venturi.</p> <p>To do this, turn off power to the unit and put a small drill bit into the nozzle to ensure that it is centered in the venturi.</p>
	Flue draft	<p>Check the draft at the flue.</p> <p>A positive draft condition may cause gas to ignite in the venturi.</p> <p>Draft should be neg .045" W.C.</p>
	Gas type	<p>Ascertain if the machine has been set up for the correct type of gas: natural or propane.</p>
	Age of burner	<p>Especially for burners that are 3 or more years old, inspect the fine mesh screen on top of the burner for signs of wear.</p> <p>A hole in the screen will allow a flame to burn through it, and, if it is close to the venturi end of the burner, the gas can ignite into the venturi.</p> <p>If this is the case, the burner cannot be repaired and it must be replaced.</p>

Troubleshooting Table for Wash Heat Steam Coil (cont.)

PROBLEM	LIKELY SOURCE OF PROBLEM	CORRECTIVE PROCEDURES
Spark at igniter rod is erratic.	Gap at igniter and rod	Check the gap at the end of the igniter and the rod. Gap may need to be decreased slightly to obtain a constant spark. Ideal gap is $\frac{1}{8}$ – $\frac{1}{4}$ inch.
	Igniter/flame rod	Inspect the igniter/flame rod for a cracked porcelain insulator. Replace the rod if any cracks are found.
	Igniter bracket	Check the igniter bracket for deterioration of the fixed rod that the spark rod arcs to. The igniter bracket may need replacement.
	High voltage ignition wire	Inspect the high voltage ignition wire for any physical damage. The wire may need to be replaced.
	Ignition wire	Inspect the ignition wire to the igniter connector to ensure that the wire is getting a good connection. Turn off the power and then disconnect the connector from the igniter. Insert a small, straight screwdriver into the connector to unscrew the internal clip and pull the wire out of the other end.

Note: Fenwal module operates with an igniter and flame sensor rod.

SECTION FOUR

RINSE/FILL SYSTEM

The Rinse/Fill system supplied with the machine is interconnected to a common line that the customer supplies hot water to.

The Rinse and Fill have dedicated solenoid valves for individual operation.

The Rinse system is normally a heated fresh water tank that is pressurized by line pressure when the machine is in a Rinse cycle (normally 30 seconds). During this time, the normally closed solenoid valve opens and the line pressure in the incoming water line forces the hot water in the Rinse tank to spray out of the Rinse jets and into the machine.

An alternative type of Rinse system for customers that have low water pressure in their building is a Pumped Rinse System.

The Fill system is normally a process a customer initiates to fill (Auto Fill) the machine when it is empty. A normally closed solenoid valve in the incoming water line opens for a pre-determined amount of time.

The machine can also be filled with a manual in line valve which would be found only on units older than 1995.

A machine with a Pumped Rinse tank has an Auto Fill system that fills and maintains the water level in the tank and operates independently from the Wash tank.

Components

Rackwasher Rinse

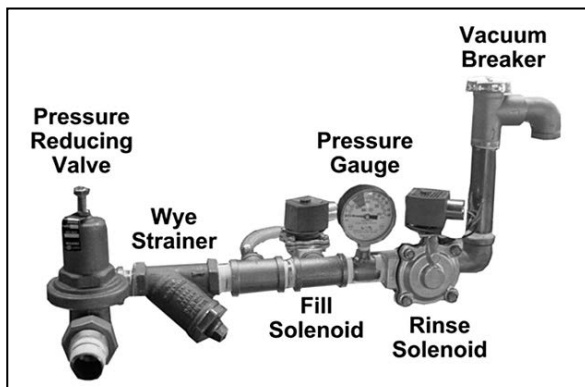

Panwasher Rinse

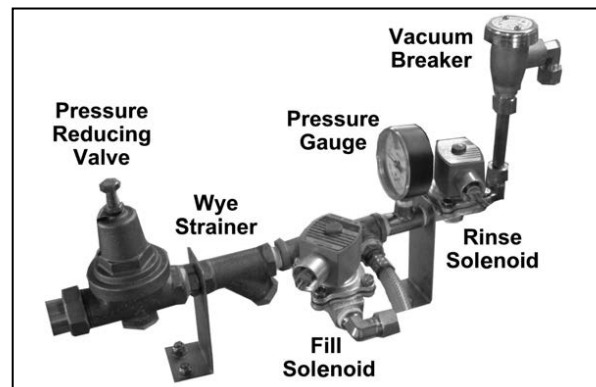

Use of a pressure-reducing valve is required if water pressure exceeds 30 psi at flow.

Troubleshooting Rinse Water System

For new installations, the rinse tank will be empty.

1. Fill the tank before the heat source is applied to it.
2. Run the machine through several cycles to fill the rinse tank.
3. Note that pumped rinse tanks do not require steps 1 and 2.

Troubleshooting Table for Rinse System

PROBLEM	LIKELY SOURCE OF PROBLEM	CORRECTIVE PROCEDURES
No flow of rinse water.	Water pressure	Water pressure on the incoming water line should be 60 psi static and 25 psi flow.
	Rinse jets	To correct possibly clogged rinse jets, remove, inspect, and clean them.
	Wye strainer	To correct a clogged Wye strainer on the incoming water line, remove the plug and clean the strainer.
	Rinse solenoid valve	To find out if the rinse solenoid valve is opening, check for voltage at Terminals #11 and #26 in the electrical panel on the machine during the rinse cycle. Voltage should be 120 V \pm 10 V. If the rinse solenoid valve has failed, it may need to be rebuilt or replaced.
	Timer or PC board	Ensure 120 V power from output of device used at Terminals #11 and 26. If not, the PC board or the timer is at fault
	Spray off hose	If equipment includes a spray off hose, check for water flow at that point. Using the spray off hose during Rinse cycle will drop water pressure.

Troubleshooting Table for Rinse System (cont.)

PROBLEM	LIKELY SOURCE OF PROBLEM	CORRECTIVE PROCEDURES
Rinse water will not stop flowing.	Rinse Cycle	<p>Check to see if Rinse cycle has ended.</p> <p>Check to see if the Run light or Rinse cycle light is illuminated.</p> <p>This can occur only on a PC board with digital display.</p>
	Timer or PC board	<p>Ensure output power from device is 0 volts at Terminals #11 and 26.</p> <p>If not, PC board or timer is at fault.</p>
	Rinse Solenoid Valve	If the rinse solenoid valve has failed, it may need to be rebuilt or replaced.

Troubleshooting The Fill System

Troubleshooting Table for Fill System

PROBLEM	LIKELY SOURCE OF PROBLEM	CORRECTIVE PROCEDURES
No flow of water is available to fill the machine.	Water pressure	<p>Check the water pressure gauge on the incoming water line. It should be 60 psi static and 25 psi flow.</p> <p>Note: Check for water flow at the spray off hose on the machine. This would indicate that there is water pressure to the machine.</p>
	Wye strainer	<p>Check the Wye strainer on the incoming water line for blockage.</p> <p>Remove the plug and clean the strainer.</p>
	Water line valve	If the machine is filled manually with a valve in the water line, the valve may have failed and may need to be replaced.
	Timer or PC board	Ensure there is 120 volt power at output of device at Terminals #11 and 15. If none, PC board or timer is at fault.

Troubleshooting Table for Fill System (cont.)

PROBLEM	LIKELY SOURCE OF PROBLEM	CORRECTIVE PROCEDURES
No flow of water is available to fill the machine. (cont.)	Fill solenoid	<p>On Auto Fill machines, check to see if the fill solenoid is being energized when it is given a signal to fill.</p> <p>At Terminals #11 and #15 in the electrical panel on the machine, check for voltage. It should be 120 V \pm10 V.</p> <p>If the fill solenoid valve has failed, it may need to be rebuilt or replaced.</p>
Machine does not fill completely.	Timed fill sequence	<p>Machines with Auto Fill have a timed fill sequence.</p> <p>When the fill was programmed, it was done at a certain line pressure.</p> <p>If there are changes in water pressure, it will affect the final level in the machine.</p>
	Auto Fill time	<p>Auto Fill time may need to be increased.</p> <p>Refer to 1827 PC Board: Programming the Auto Fill or Timers: Omron Timers, or Digital Touch Pad Programming, depending on which type of controls are present.</p>
	Spray off hose	Using the spray off hose during the Fill mode will drop the water pressure and cause a short Fill.
Auto Fill will not stop flowing.	Auto Fill timer	<p>Check to see if the Auto Fill timer has timed out.</p> <p>Depending on the type of Auto Fill system in the machine, try to determine if the timer is still energized.</p>
	Timer or PC board	<p>Ensure that power is getting to the Fill solenoid.</p> <p>Ensure output power from device is 0 volts at Terminals #11 and 15.</p> <p>If not, device is at fault.</p>
	Auto Fill solenoid	The Auto Fill solenoid valve may have failed. The valve may need to be rebuilt or replaced.

SECTION FIVE

AUTO DRAIN

The Auto Drain system supplied with the machine is an option that was installed to convert the manual drain valve to a motor-operated drain valve on the machine.

The Auto Drain valve is operated by a switch on the front of the machine. By opening the Auto Drain valve, the water in the wash tank of the machine will gravity drain out of the tank. The overflow in the machine would operate the same as a machine with a manual drain.

Another type of Auto Drain is a pumped type. This system consists of a pump that is used to drain the wash tank of the machine. The drain pump maintains the water level in the wash tank via a float switch. (There is no need for an overflow in this type of system.)

When the machine is turned off, the drain pump will come on and pump out the water in the wash tank. This will shut off after a pre-determined time.

KF Contromatics Auto Drain Valve

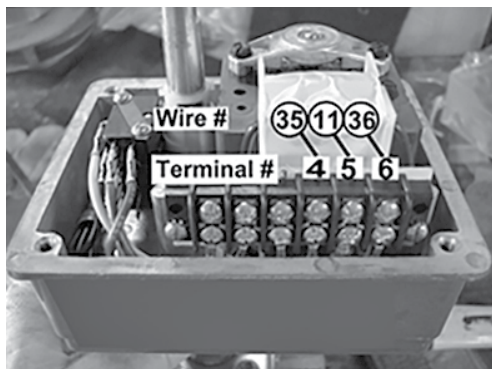

Unitorq Auto Drain Valve

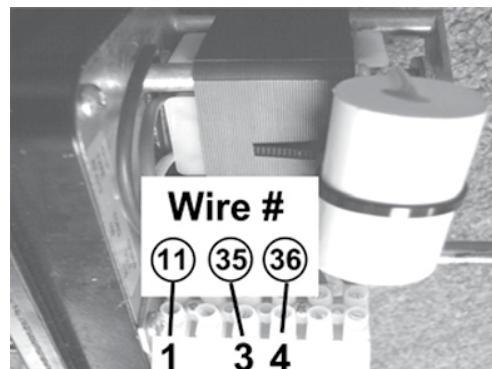

Valwork Valve

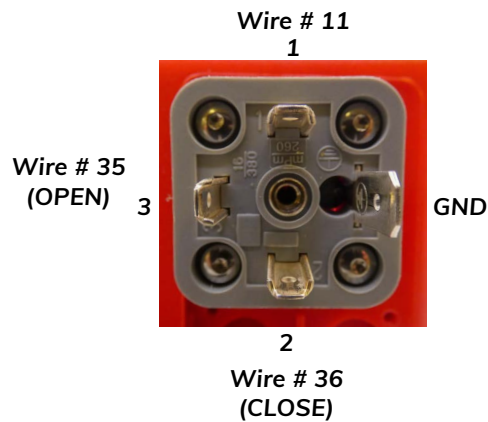

NOTE: The Auto Drain Valve is operable only when the machine control power is switched off.

Troubleshooting

Troubleshooting Table for Auto Drain

PROBLEM	LIKELY SOURCE OF PROBLEM	CORRECTIVE PROCEDURES
Auto Drain valve will not operate.	Power switch	Check that switch is in the Off position.
	Touch pad	<p>Check the touch pad power button to confirm that a colon is illuminated.</p> <p>With the normal control voltage shut off to the machine, the voltage is supplied to the Auto Drain switch.</p> <p>Note: The Auto Drain valve cannot be operated while the machine is in operation.</p>
	Control Panel	<p>Check for voltage at Terminal #11 (neutral) and Wire #3 (hot).</p> <p>Voltage should be 120 ± 10 volts.</p>
	Voltage	<p>Check for voltage at the Auto Drain valve. With the switch turned to the Open position, Wire #35 should be energized (120V).</p> <p>With the switch turned to the Closed position, Wire #36 should be energized.</p>
Valve will not fully close or open.	Limit switches	<p>On top of the Auto Drain valve is a control box that contains the electrical components that operate the valve.</p> <p>There are limit switches that control what position the valve stops at.</p> <p>On the valve shaft, there is a cam that contacts the limit switch.</p> <p>The cam may need to be adjusted so that the proper operation of the valve can be achieved.</p>

Troubleshooting Auto Drain (Pumped)

Troubleshooting Table for Auto Drain (Pumped)

PROBLEM	LIKELY SOURCE OF PROBLEM	CORRECTIVE PROCEDURES
Drain pump will not shut off.	Float switch	<p>Check the float switch inside the machine.</p> <p>Inspect the float for dirt or debris that could cause it to stick closed. It should move freely up and down.</p> <p>Note: If the float switch needs to be replaced, it must be mounted with the float facing downward. See illustration of switch in normally open position.</p>
	Timer	<p>Check the timer on the electrical panel that controls the pump-out time. This timer will have a resistor mounted on it.</p> <p>Adjust time on Omron timer if applicable.</p> <p>The timer contact is normally closed and should open after no more than about five minutes.</p> <p>The timer may then need to be replaced.</p>
	Control relay	<p>Check the control relay on the electrical panel. Remove the relay and check for welded contacts. The relay may need to be replaced.</p>
Drain pump will not come on.	Float switch	<p>Check the float switch inside the machine.</p> <p>Inspect the float for dirt or debris that could cause it not to float upwards.</p> <p>Also confirm that the float is intact on the stem.</p> <p>It is possible for the float to come off of the stem and be somewhere inside of the machine.</p> <p>The float switch may need to be replaced.</p>
	Control relay	<p>Check the control relay on the electrical panel. The relay may need to be replaced.</p>
		<p>Check the delay timer (15 sec.) on the electrical panel.</p> <p>Timer contact is normally open, and it closes after 15 seconds.</p> <p>The timer may need to be replaced.</p>

Troubleshooting Table for Auto Drain (cont.)

PROBLEM	LIKELY SOURCE OF PROBLEM	CORRECTIVE PROCEDURES
Drain pump will not come on. (cont.)	Drain pump motor	<p>Check the drain pump motor.</p> <p>With power on to the machine, raise the float switch inside of the machine and hold it for at least 15 seconds.</p> <p>Pump motor should turn on.</p> <p>Pump motor may need to be replaced.</p>
Water level in the machine disappears.	Discharge pipe	<p>The discharge piping on the Auto Drain pump should include an anti-siphon type piping system.</p> <p>If the machine is not piped in this manner, it is possible for the pump to shut off and create a siphon to empty the wash tank of the machine.</p>
Auto Drain pump is not emptying the wash tank.	Drain piping/ drain pump/ filter basket	<p>Check for dirt, debris, or any other form of blockage in the drain piping.</p> <p>Check for dirt or debris in the drain pump.</p> <p>Check for dirt or debris in the filter basket.</p>
	Pre-mature shutoff	<p>If the pump is shutting off prematurely, the pump-out time may need to be increased.</p> <p>This would involve changing out the resistor on the pump-out timer on the electrical panel.</p> <p>Adjust time on Omron timer if applicable.</p>
Auto Drain pump runs dry	Drain pump motor	<p>Normally, the drain pump motor shuts off at or about the time when the wash tank is empty.</p> <p>The pump should not be run dry for any longer than 10 minutes.</p> <p>The plastic may freeze onto the spindle.</p>
	Pump-out time	<p>The pump-out time can be decreased to better protect the pump.</p> <p>This would involve changing out the resistor on the pump-out timer on the electrical panel.</p> <p>Adjust time on Omron timer if applicable.</p>

SECTION SIX

INSTALLATION OF UTILITIES

ELECTRICAL

Warning: Before attempting to do any wiring in the electrical panel, ensure that all power is turned off.

All electrical connections should be made by a qualified electrician. They should comply with all local, state, and federal codes.

Install single or 3 phase main connection.

- a. Refer to the specific electrical drawing and/or specification sheet supplied with the machine.
- b. Observe recommended service size and voltage.
- c. Connect to the power distribution block.
- d. Connect suitable ground to ground lug.

Panwasher Electrical Connections

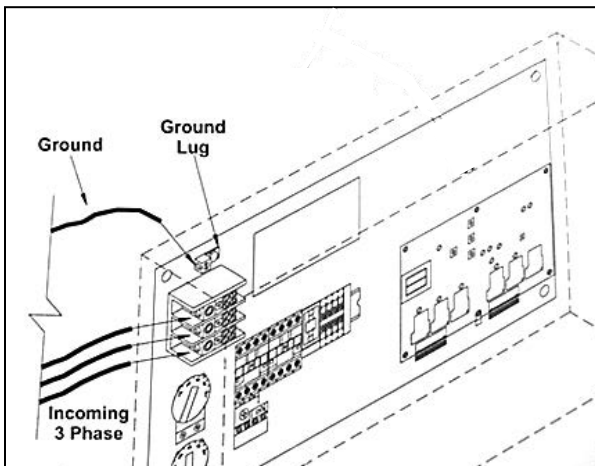

Rackwasher Electrical Connections

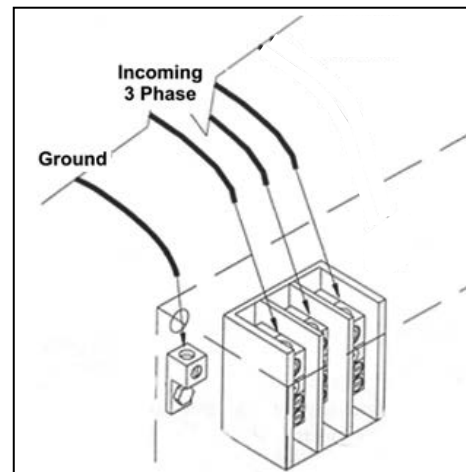

You should install a supply disconnect for the 3 ph power.

GAS

It is very common for a washer to be installed at the end of a building's supply line. There may be proper supply pressure but not enough volume.

Ensure that the supply lines are of proper size to support the running BTU's.

Use the proper method for installing incoming gas lines on both panwashers and rackwashers.

Incoming Gas Lines for Panwashers and Rackwashers

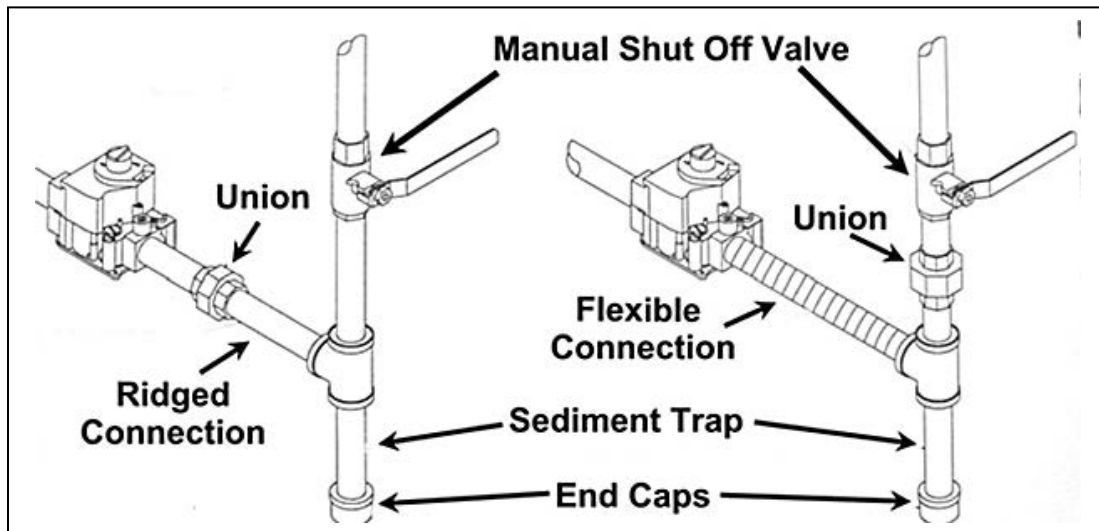

1. If it is not possible to install a shut off valve and union as shown in the illustration, install these items as close to the gas valve as possible.
2. For BTU's, the number of lines needed and the size of incoming gas lines, refer to installation sheet and/or specification sheet.
3. Note that even if the specification only calls for a $\frac{3}{4}$ " line, the supply line feeding that $\frac{3}{4}$ " line may need to be larger, depending on the length of the run from the main line.
4. Always run separate lines from a main trunk line to each connection.
5. Always follow all local, state, and federal codes when installing gas lines.
6. Ensure that incoming gas pressure is maintained between 6" - 14" W.C. for natural gas and between 11" - 14" W.C. propane. Failure to maintain these pressures may cause operational problems and void the warranty on the gas burner.
7. Determine whether the local code allows flexible connections in gas lines.

PLUMBING

Water supply lines must be equal to or larger than the factory supplied connection point. Water pressure should be 60 psi static and 20 psi flow. Incoming water temperature needs to be between 120 °and 140° F.

Failure to maintain this supply will have a negative effect on the Fill time and the Rinse coverage, as well as the time to heat up the Wash and Rinse tanks.

Incoming Water Supply

Use recommended procedures for connecting to the incoming water supply.

Panwasher Incoming Water Connections

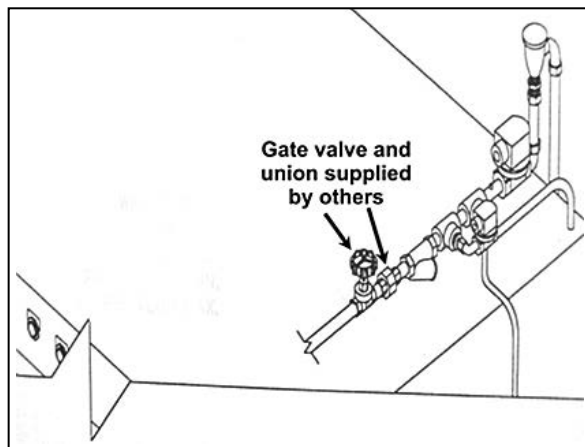

Rackwasher Incoming Water Connections

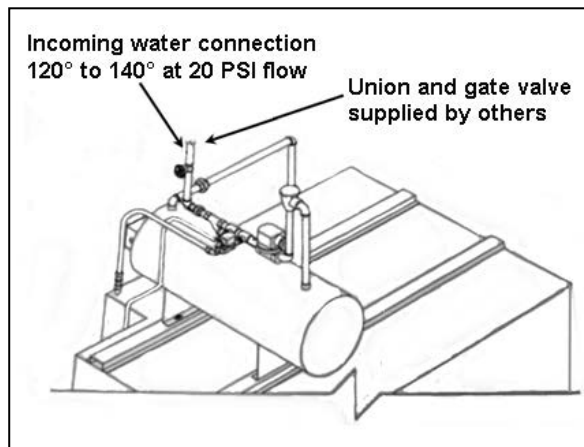

The use of a pressure reducing valve will be required if the water pressure is over 30 psi at flow.

If installing a (P.R.V.), do so between the union and Wye strainer.

1. For incoming water pipe size, refer to the installation drawing or specification sheet.
2. Ensure that incoming water temperature is between 120° and 140° Fahrenheit.
3. Note that Wash Tank Fill time depends on the specific model. Maximum usage occurs after wash tank is full.
4. Ensure that incoming water pressure is 20 psi minimum flow and 60 psi static max.
5. Note that failure to maintain the proper pressure may void the rinse tank warranty.
6. When connecting an incoming water supply, install a shut off valve and a union at the location shown or as close to machine as possible.

DRAIN

Follow the recommended procedures for drain connections.

1. If the drain and overflow lines are interconnected, ensure that the overflow line is connected on the out going side of the drain valve.
2. If the drain and overflow lines are connected separately, ensure that the floor drain is large enough to accept both lines.
3. If the drain and overflow lines are interconnected on a rackwasher in a pit, ensure that both lines run far enough away from the machine that splashing water does not affect any components of the washer. It is not necessary for the lines to run all the way to the pit drain.
4. Note that it is acceptable to have separate drain and overflow lines on a rackwasher in a pit as long as splashing water does not affect any of the washer components.
5. When running drain and overflow lines to a rackwasher that is not in a pit, ensure that the overflow line is connected on the out going side of the drain valve.
6. When running drain lines, be sure to maintain a minimum $\frac{1}{4}$ " of slope to every 12" of distance.
7. Use suitable materials for drain and overflow lines, including CPVC, copper, brass, or stainless steel.

Panwasher Drain Connections

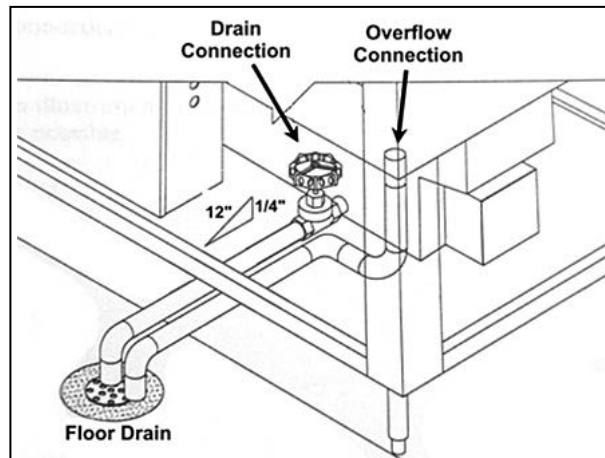
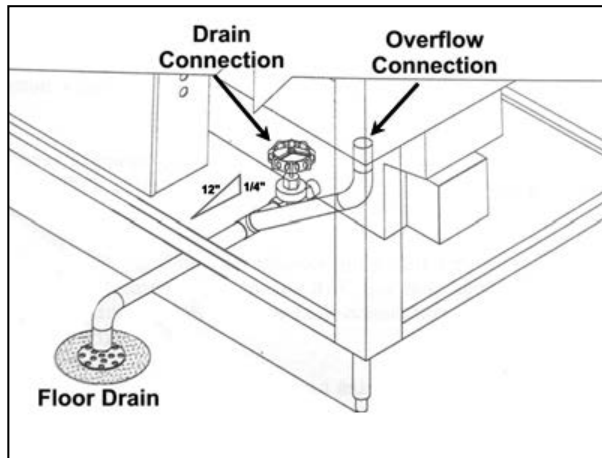

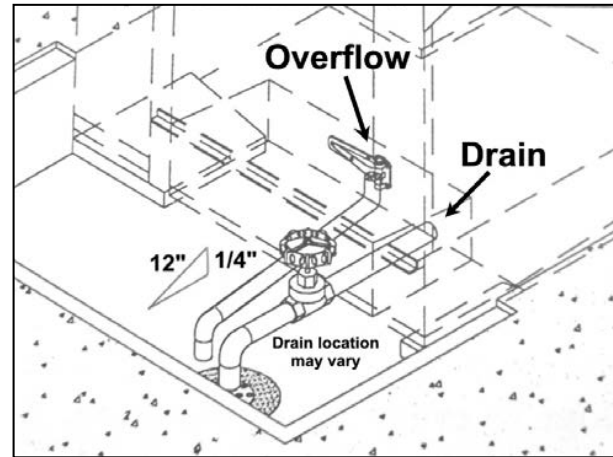
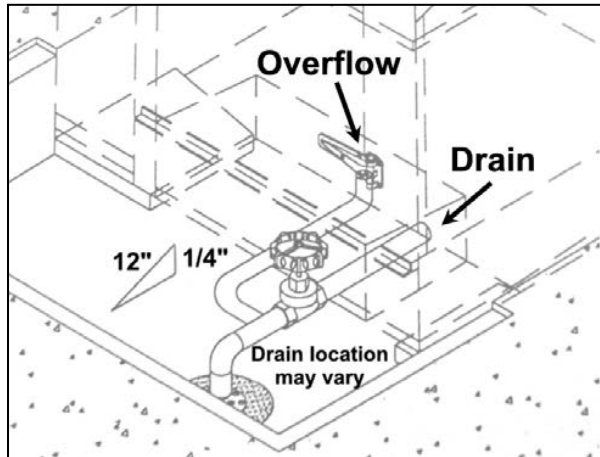
Rackwasher Drain Connections**VENTING**

Follow the recommended procedures for drain connections.

Gas Flue

It is very important to correctly install the gas flue. If the flue is not correct, then many problems with the heating systems can occur. Consistent performance and the ability to maintain correct temperatures depend on proper installation.

Douglas Machines Corp. uses two types of gas burner systems: a normally aspirated infrared system, and a power blower open flame system.

Adhere to the guidelines in the manual and to all local, state, and federal codes.

Refer to the installation sheet and/or the specification sheet per specific model for BTU ratings.

1. Size the flue according to BTU rating and distance of run.
2. Use only B-type flue material.
3. Maintain a negative .045" W.C. draft. Failure to maintain this level prevents the ability to achieve correct operating temperatures and may cause the warranty to become void.
4. To achieve the required draft, it may be necessary to use either a barometric draft control or a draft inducing fan.

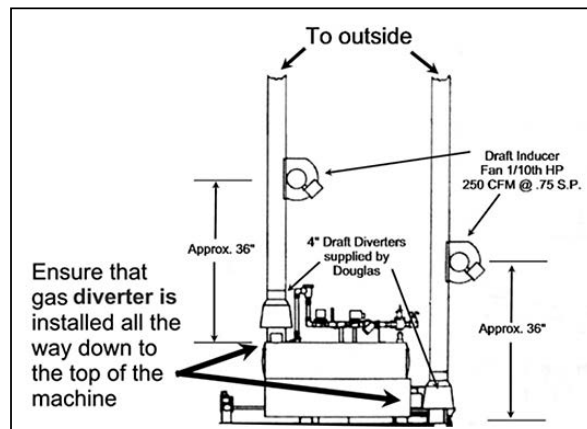
Rackwasher and Panwasher Gas Flue Venting

5. If any 45° or 90° bends or any horizontal runs are used in the gas flue, the chances of having to use the draft control or the draft inducing fan are increased. The fan should have a rating of at least 175 C.F.M. at $\frac{3}{4}$ " static pressure. Electric power will need to be supplied to the fan, and the machine is not prewired, unless ordered with fans.

NOTE: If installing a unit under a hood, install a short section of duct pipe to each flue to ensure fumes are contained by the hood.

6. Before mounting the barometric draft control approximately 6" above the top of the machine, remove the factory supplied diverter.
7. If a draft inducer fan is required, mount it in the center of the horizontal run.
8. If no horizontal run is used, mount the fan 3 to 4 feet above the barometric draft control or the draft diverter.
9. It is best to run the wash and rinse flues separately.
10. If the wash and rinse flues must be interconnected, comply with these requirements:
 - a. Possibly provide a separate barometric draft control or inducing fan for both wash and rinse flue pipes.
 - b. Use a Y-configuration when connecting individual flue lines to the main flue.
 - c. Possibly use a draft inducing fan upstream of the Y-connection.
 - d. Maintain a negative .045" W.C. draft on each individual flue, measured as close to the pipe connection to the machine as possible.

Steam Exhaust Venting

Steam extraction venting is very important. If it is not correctly installed, it could produce an overabundance of steam, as well as water, coming out of the door. These conditions could occur both during operation and upon completion of the cycle.

Follow the installation guidelines in this manual as well as all local, state, and federal codes.

Installing the rackwasher venting

1. Install the venting in the most efficient and direct manner possible.
2. Observe the connection for a hood fan and a cabinet fan.

Rackwasher with Multiple Steam Vent Connections

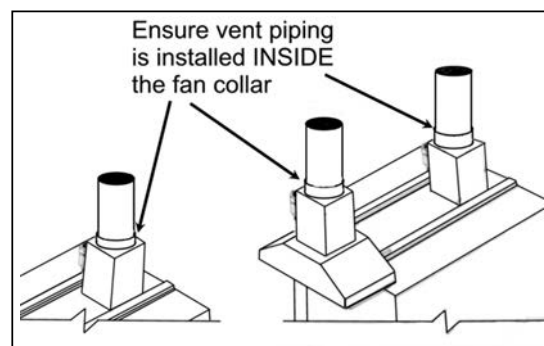

3. Note the single point connection for the cabinet only. Note: Recommended procedure is to run a vent pipe for each exhaust fan.
4. Interconnect the hood fan and the cabinet fan, if needed, using a Y-connection but not a tee configuration.
5. Avoid using 90° bends if at all possible, and 45° bends are preferred.
6. If 90° bends and horizontal runs are used, an inline fan to assist venting may be required.
7. Keep all horizontal runs as short as possible, and put a pitch in them so any collection of condensation will return to the machine.
8. If a fan other than the one purchased with the unit is needed or used, ensure that it is wired to operate only after Wash and Rinse cycles are complete. If the fan is wired incorrectly and operates during the cycles, it will not be possible to maintain operating temperatures. A hood fan may be wired to run as long as the unit is turned on.

Contact the factory for details.

Installing the panwasher venting

1. Install the steam extraction fan in the duct. The duct material may be PVC, galvanized, or S.S. See instructions in the fan box.
2. Connect the plastic conduit and wire on top of machine labeled "steam extraction fan" to the fan. The washer will be prewired for the fan, if ordered with fan. If not, see electric schematic for power supply connections.
3. Follow all procedures for proper vent installation, according to local codes.
4. If the machine is located under a complete hood, install a short steam vent pipe approximately 24" tall to prevent water spraying out of the vent collar and accumulating on top of the machine.
5. Use a steam extraction fan to draw steam from the cabinet after the Rinse cycle.

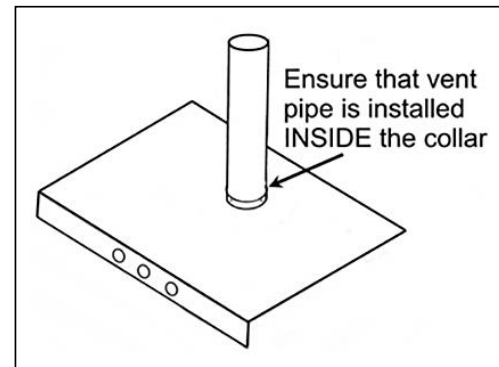

Install Procedure for Venting on a Panwasher

Refer to the electric schematic for power supply.

Vent Size and Recommended Duct Materials

EQUIPMENT	PVC SIZE	VENT COLLAR SIZE
Rackwasher	12"	12 7/8 " I.D.
Panwasher	6"	6 5/8" I.D.
Rackwasher Hood	17" O.D. Flange W/(8) 7/16" Holes pn 16 1/8 Centers	

Steam Supply and Return Lines

1. Before installing the incoming and return steam lines for panwasher and rackwasher rinse tanks, study the illustration for the proper method.

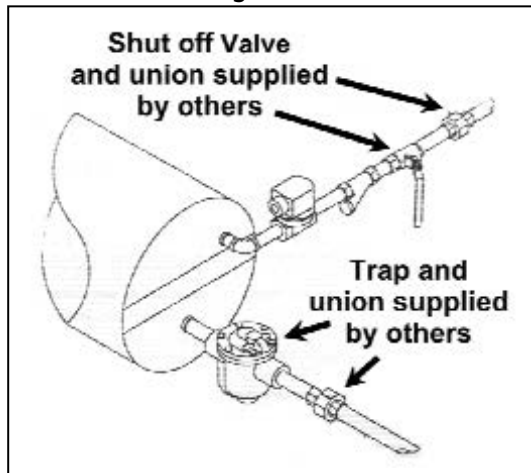
Rinse Tank Incoming and Return Steam Lines

Incoming steam supply should not exceed 80 psi.

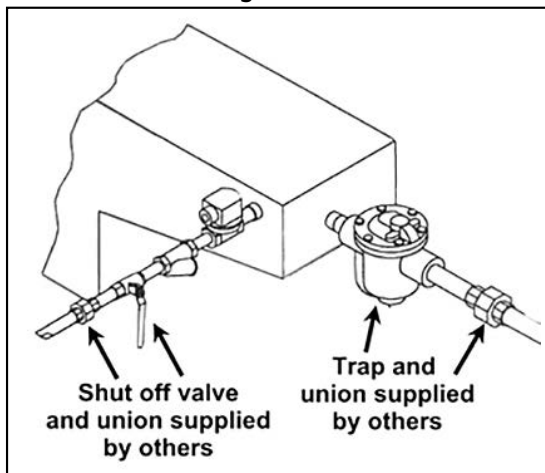
Wash Tank Incoming and Return Steam Lines

Incoming steam supply should not exceed 80 psi.

3. Refer to the installation sheet and/or specification sheet for consumption, location, and size of incoming and return steam lines.
4. Install unions and steam traps as shown in illustrations.
5. If returning to the boiler, ensure that all valves on the return line are fully open when starting.
6. If a live steam system is used, check the installation sheet for location and size of incoming steam line.
7. Check specification sheet for consumption.
8. Supply pressure should be 15 psi min. and 80 psi max.

SECTION SEVEN

REFERENCE

Reference : Fan, Hood Fan, & Pump Motor Control Components

MOTOR H.P.	KVA CODE	VOLTAGE	FLA	WIRE AWG	AMPERAGE BREAKER / FUSE	BREAKER PART #	FUSE PART #	CONTACTOR	CONTACTOR PART #	OVERLOAD	OVERLOAD PART #
Fan Motors											
0.33	N	208	1.9	#14	3/3	8686		LC1 K0610	1243	LR2K0308	1256
0.33	N	230	1.6	#14	3/3	8686		LC1 K0610	1243	LR2K0307	2248
0.33	N	460	0.8	#14	3/3	8686		LC1 K0610	1243	LR2K0306	1255
0.33	N	575	0.64	#14	3 FUSE		5597	LC1 K0610	1243	LR2K0305	3864
0.5	M	208	2.1	#14	6/6	10376		LC1 K0610	1243	LR2K0308	1256
0.5	M	230	2	#14	6/6	10376		LC1 K0610	1243	LR2K0308	1256
0.5	M	460	1	#14	3/3	8686		LC1 K0610	1243	LR2K0306	1255
0.5		575	0.8	#14	3 FUSE		5597	LC1 K0610	1243	LR2K0305	3864
0.75	M	208	3	#14	6/6	10376		LC1 K0610	1243	LR2 K0310	1500
0.75	M	230	2.8	#14	6/6	10376		LC1 K0610	1243	LR2 K0310	1500
0.75	M	460	1.4	#14	3/3	8686		LC1 K0610	1243	LR2 K0307	2248
0.75	K	575	1.2	#14	3 FUSE		5597	LC1 K0610	1243	LR2 K0307	2248
Hood Fan Motors											
1	M	208	3.7	#14	6/6	10376		LC1 D09G7	1213	LRD-08	5007
1	M	230	3.4	#14	6/6	10376		LC1 D09G7	1213	LRD-08	5007
1	M	460	1.7	#14	3/3	8686		LC1 K0610	1243	LR2 K0307	2248
1		575									
1.5	K	208	4.4	#14	10/10	10377	0177	LC1 D09G7	1213	LRD-10	4531
1.5	K	230	4.2	#14	10/10	10377	0177	LC1 D09G7	1213	LRD-10	4531
1.5	K	460	2.1	#14	6/6	10376	5741	LC1 K0610	1243	LR2 K0308	1256
1.5	L	575	1.5	#14	3 FUSE		5597	LC1 K0610	1243	LR2 K0307	2248
Pump Motors											
0.75	J	208	2.7	#14	6/6	10376		LC1 K0610	1243	LR2 K0310	1500
0.75	J	230	2.9	#14	6/6	10376		LC1 K0610	1243	LR2 K0310	1500

MOTOR H.P.	KVA	VOLTAGE	WIRE	AMPERAGE BREAKER / FUSE	BREAKER PART #	FUSE PART #	CONTACTOR	CONTACTOR PART #	OVERLOAD	OVERLOAD PART #	
0.75	J	460	1.45	#14	3/3	8686		LC1 K0610	1243	LR2 K0307	2248
0.75	M	575	1	#14	3 FUSE		5597	LC1 K0610	1243	LR2 K0306	1255
1	K	208	3.2	#14	6/6	10376		LC1 K0610	1243	LR2K0310	1500
1	K	230	3.2	#14	6/6	10376		LC1 K0610	1243	LR2K0310	1500
1	K	460	1.6	#14	3/3	8686		LC1 K0610	1243	LR2K0307	2248
1		575									
1.5	N	208	4.1	#14	10/10	10377	0177	LC1 D12G7	1209	LRD10	4531
1.5	N	230	4	#14	10/10	10377	0177	LC1 D12G7	1209	LRD10	4531
1.5	N	460	2	#14	6/6	10376	5741	LC1 K0610	1243	LR2 K0308	1256
1.5		575	1.5		6 FUSE		5741	LC1 K0610	1243	LR2 K0308	1256
2	L	208	5.6	#14	10/10	10377	0177	LC1 D09G7	1213	LRD-12	1212
2	L	230	5.4	#14	10/10	10377	0177	LC1 D09G7	1213	LRD-12	1212
2	L	460	2.7	#14	10/10	10377	5729	LC1 K0610	1243	LR2K0310	1500
2		575									
3	K	208	8.5	#14	20/20	10378	1148	LC1 D18G7	1210	LRD-14	1249
3	K	230	7.6	#14	20/20	10378	1148	LC1 D12G7	1209	LRD-14	1249
3	K	460	3.8	#14	10/10	10377	5729	LC1 K0610	1243	LR2K0312	2250
3		575									
5	J	208	13	#12	20 / 25	10378	1149	LC1 D25G7	1244	LRD-21	1250
5	J	230	12.2	#12	20 / 25	10378	1149	LC1 D25G7	1244	LRD-21	1250
5	J	460	6.1	#14	10 / 15	10377	5725	LC1 D12G7	1209	LRD-12	1212
5	K	575	4.8	#14	15 FUSE		5725	LC1 D12G7	1209	LRD-10	4531

Reference : Pump Motor & Control Components

MOTOR H.P.	KVA CODE	VOLTAGE	FLA	AWG	AMPERAGE BREAKER / FUSE	BREAKER PART #	FUSE PART #	CONTACTOR	CONTACTOR PART #	OVERLOAD	OVERLOAD PART #
7.5	J	208	18.8	#10	25 / 30	10379	1150	LC1 D32G7	1238	LRD-22	1251
7.5	J	230	17.4	#10	25 / 30	10379	1150	LC1 D32G7	1238	LRD-22	1251
7.5	J	460	8.7	#14	20 / 25	10378	5724	LC1 D18G7	1210	LRD-16	1211
7.5	J	575	7.2	#14	15 FUSE		5725	LC1 D12G7	1209	LRD-14	1249
10		208	27	#8	40 / 50	10381		LC1 D32G7	1238	LRD-32	1252
10		230	25	#10	40 / 50	10381		LC1 D32G7	1238	LRD-32	1252
10		460	12.5	#14	20 / 25	10378		LC1 D18G7	1210	LRD-21	1250
10		575									
15	G	208	39	#6	63 / 70	10386		LC1 D50AG7	8991	LRD-350	8992
15	G	230	36	#6	63 / 70	10386		LC1 D50AG7	8991	LRD-350	8992
15	G	460	18	#10	30 / 40	10384		LC1 D25G7	1244	LRD-22	1251
15	G	575	14.5	#12	25 FUSE		5724	LC1 D18G7	1210	LRD-21	1250
20	G	208	52.6	#4	80 / 90	8979		LC1 D65AG7	8980	LRD-365	8981
20	G	230	47	#4	80 / 90	8979		LC1 D65AG7	8980	LRD-365	8981
20	G	460	23.5	#10	Motor Starter	10573		LC1 D32G7	1238	Trip Contact	10574
20		575	18.6	#10	25 FUSE		5724	LC1 D25G7	1244	LRD-22	1251
25	F	208	68	#4	100/100	4876		LC1 D80G7	1248	LRD-3363	1882
25	F	230	58	#4	80/80	8979		LC1 D80G7	1248	LRD-3361	5614
25	F	460	29	#8	Motor Starter	10573		LC1 D40AG7	8994	Trip Contact	10574
25		575	21.4	#10	40 FUSE		4779	LC1 D32G7	1238	LRD-22	1251
PUMP MOTORS SINGLE PHASE											
2	H	230	9	#14	15/15	10374	1147	LC1 D12G7	1209	LRD-16	1211
3	G	230	14	#12	25/25	10379		LC1 D25G7	1244	LRD21	1250
5	H	208	23	#10	30/30	10384	1150	LC1 D32G7	1238	LRD-32	1252
5		230	21.5	#10	30/30	10384	1150	LC1 D32G7	1238	LRD-32	1252
7.5	G	208	32	#8	50/50	10385		LC1 D50AG7	8991	LRD-340	8995
7.5	G	230	29	#8	50/50	10385		LC1 D50AG7	8991	LRD-340	8995

Reference : Heating Elements Control Components

K.W.	VOLTAGE	AMPS	WIRE AWG	HEATERS AMPERAGE BREAKER / FUSE	3 PHASE BREAKER PART #	FUSE PART #	CONTRATOR	CONTACTOR PART #
3	208	8.32	#14	15/15	10374	1147	LC1 K0610	1243
3	240	7.21	#14	10/10	10377	0177	LC1 K0610	1243
3	480	3.6	#14	6/6	10376	5741	LC1 K0610	1243
6	208		#12	25/25	10379	1149	LC1 D09G7	1213
6	240		#12	20/20	10378	1148	LC1 D09G7	1213
6	480	7.21	#14	10/10	10377	5729	LC1 K0610	1243
6	575	6.02	#14	10 FUSE		5729	LC1 K0610	1243
12	208		#8	50	10382		LC1 D25G7	1244
12	240		#8	40	10381		LC1 D18G7	1210
12	480		#12	20	10378		LC1 D09G7	1213
12	575		#14	20 FUSE		5716	LC1 D09G7	1213
18	208		#6	63/70	10386		LC1 D32G7	1238
18	240		#6	63/60	10386		LC1 D32G7	1238
18	480		#10	30/30	10384		LC1 D12G7	1209
18	575		#12	25 FUSE		5724	LC1 D09G7	1213
24	208		#4	80	8979		LC1 D50AG7	8991
24	240		#4	80	8979		LC1 D50AG7	8991
24	480		#8	USE 18 & 6kw				
24	575		#10	35 FUSE		5736	LC1 D18G7	1210
HEATERS SINGLE PHASE								
3	208		#14	20/20	10378	1148	LC1 K0610	1243
3	240		#14	20/20	10378	1148	LC1 K0610	1243
6	208		#10	40/40	10381		LC1 D18G7	1210
6	240		#10	30/30	10380	1150	LC1 D18G7	1210
12	240		#6	63/70	10383		LC1 D32G7	1238

Reference : Breakers

				POLE	AMPERAGE BREAKER	BREAKER PART #					
BREAKERS											
				3	30A D-Curve	10384					
				3	50A D-Curve	10385					
				3	63A D-Curve	10386					
				1	0.5A	10332					
				1	1A	10333					
				1	3A	10334					
				1	5A	8635					
				1	8A	10335					
				1	10A	7459					
				1	15A	7460					
				1	20A	7461					
				1	30A	7462					

Reference : Overloads

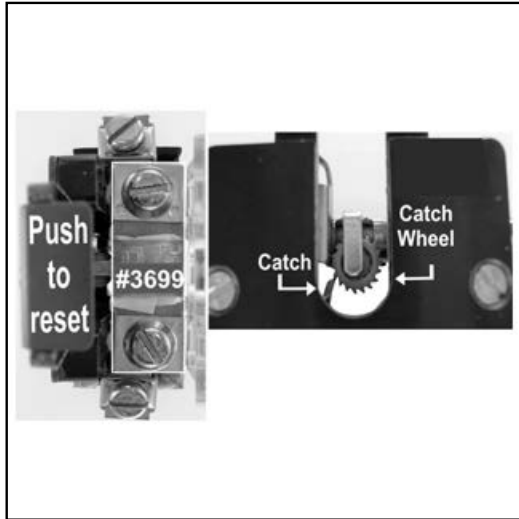

Overload and Holder for Oscillating Arms

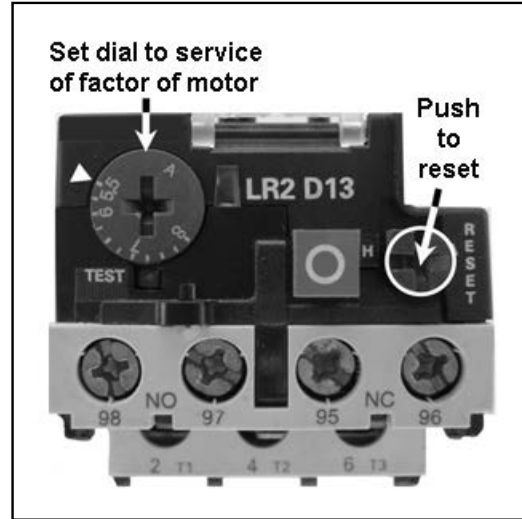

Used from 1993-2003

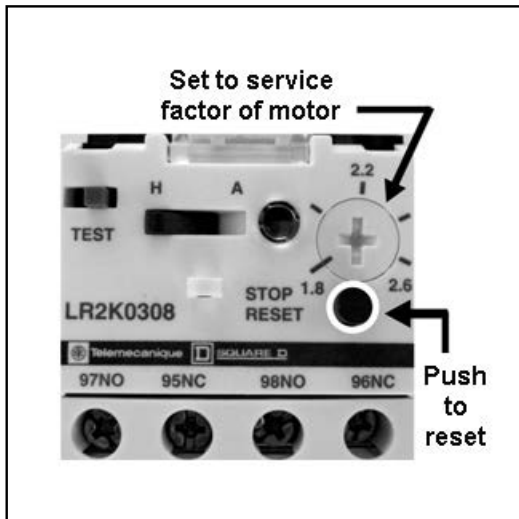

Currently in Use

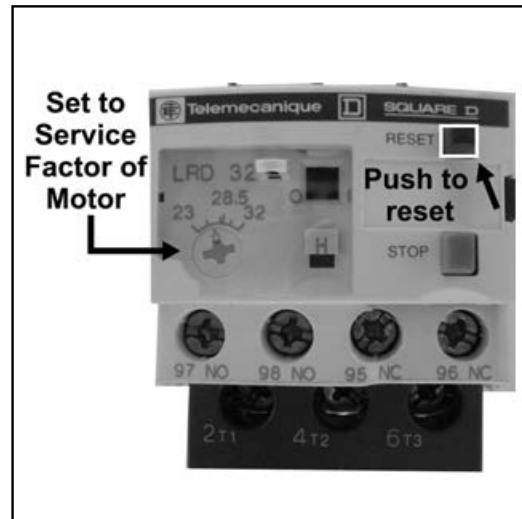

Currently in Use

Thank You!

For Partnering with
Douglas Washing & Sanitizing Systems.

REDUCE DOWNTIME

Save money and reduce down time by having the parts on hand with our Platinum, Gold, Silver kits.

PARTS & SERVICE UPTIME MAINTENANCE KITS

All the resources
you'll ever need in one place.

(800) 331-6870

www.douglasmac.com

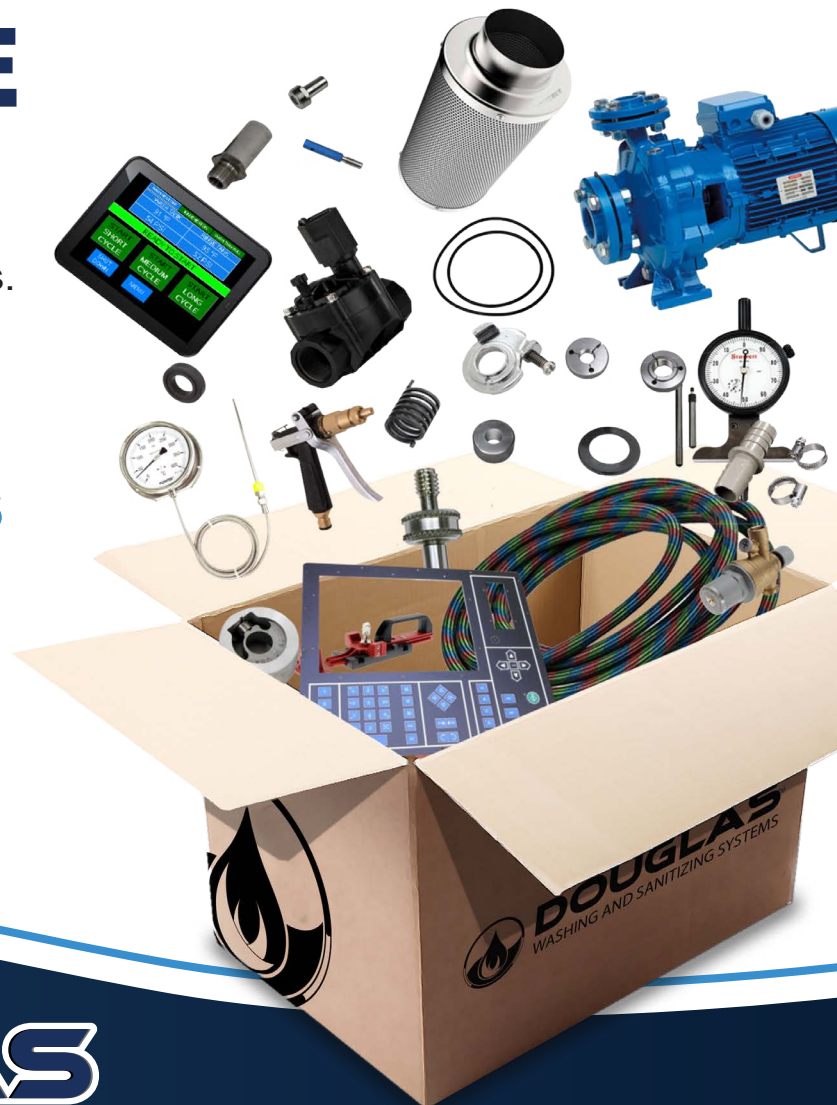

DOUGLAS
WASHING AND SANITIZING SYSTEMS